

Underfloor heating system
Riscaldamento a pavimento



E-DRY EVO

Radiant floor system without concrete
Sistema di riscaldamento a pavimento a secco



INSTALLATION MANUAL
MANUALE INSTALLAZIONE



SAFETY WARNINGS - AVVERTENZE PER LA SICUREZZA

Please, read this manual before installation and/or use of the equipment and keep it in an accessible place.

This equipment is part of complex installation; the designer's responsibility has to draw up the thermal diagram and statically verify the supporting structures.

The manufacturer's technical department is available at the phone numbers listed on the back of this manual for advice or particular technical requests.

CAUTION

Installation and maintenance should be performed by qualified personnel only.

Hydraulic systems and rooms in which the equipment is to be installed must meet the required standards regarding safety, accident and fire prevention currently in force in the country of use.

Leggere con attenzione questo manuale prima dell'installazione e/o dell'uso dell'apparecchiatura e conservarlo in un luogo accessibile.

La presente apparecchiatura costituisce un componente che fa parte di installazioni complesse: è compito del progettista redigere lo schema termico e verificare staticamente le strutture portanti.

L'ufficio tecnico del Costruttore si rende disponibile ai numeri indicati sul retro del presente manuale per consulenze o richieste tecniche particolari.

ATTENZIONE

L'installazione e la manutenzione vanno eseguiti solo da personale qualificato.

Gli impianti idraulici ed i locali di installazione delle apparecchiature devono rispondere alle norme di sicurezza, antinfortunistiche e antincendio in vigore nel Paese di utilizzo.



GENERAL WARNINGS - AVVERTENZE GENERALI

- *If after unpacking the packages any anomaly is noted, do not proceed with the installation and call an authorized service centre of the manufacturer.*
- *After installation, dispose of the packaging as required by regulations currently in force in the country of use.*
- *Always demand genuine parts: failure to observe this rule will invalidate the warranty.*
- *The manufacturer will not be held responsible under any circumstances for the following cases:*
 - *Where the safety regulations and safety standards outlined above are not complied with, including those in force in the country of installation.*
 - *Failure to follow the directions contained in this manual.*
 - *Damage to people, animals or property resulting from improper installation and/or misuse of products or equipment.*
 - *Inaccuracies or typographical or transcription errors and in this manual.*
 - *Furthermore, the manufacturer reserves the right to stop production at any time and to make any changes they deem necessary or useful, without the obligation of prior notice.*

- Se dopo aver disimballato i colli si nota una qualsiasi anomalia, non procedere all'installazione e rivolgersi ad un Centro di Assistenza autorizzato dal Costruttore.
- Alla fine dell'installazione smaltire gli imballi secondo quanto previsto dalle normative in vigore nel Paese di utilizzo.
- Esigere solo ricambi originali: la mancata osservazione di questa norma fa decadere la garanzia.
- Il Costruttore declina ogni responsabilità nei casi seguenti:
 - Non vengano rispettate le avvertenze e le norme di sicurezza sopra indicate, comprese quelle vigenti nei paesi di installazione.
 - Mancata osservanza delle indicazioni segnalate nel presente manuale.
 - Danni a persone, animali o cose, derivanti da una errata installazione e/o uso improprio di prodotti e attrezzature.
 - Inesattezze o errori di stampa e trascrizione contenuti nel presente manuale.
 - Il Costruttore, inoltre, si riserva il diritto di cessare la produzione in qualsiasi momento e di apportare tutte le modifiche che riterrà utili o necessarie senza obbligo di preavviso.



WARNING

Before laying the FLOORING , carefully read the instructions mentioned in this chapter.



ATTENZIONE

Prima di iniziare la posa dei RIVESTIMENTI consultare attentamente le indicazioni riportate nel relativo capitolo



DISPOSAL - SMALTIMENTO



In accordance with the provisions of the following European directives 2011/65/EU, 2012/19/EU and 2003/108/EC, regarding reducing the use of hazardous substances in electrical and electronic equipment, in addition to waste disposal.



In base a quanto previsto dalle seguenti direttive europee 2011/65/UE, 2012/19/UE e 2003/108/CE, relative alla riduzione dell'uso di sostanze pericolose nelle apparecchiature elettriche ed elettroniche, nonché allo smaltimento dei rifiuti.

The crossed out wheelie bins symbol on the equipment indicates that, at the end of its useful life, the product must be collected separately from general waste.

Therefore, at the end of its useful life, the user must take the equipment to a designated electrical and electronic waste collection point, or return it to the dealer that, against the purchase of an equivalent appliance, it is obliged to collect the product for disposal free of charge.

Appropriate differentiated waste collection for subsequent recycling, treatment and environment-friendly disposal of the discarded equipment helps preventing possible negative environmental and health effects and encourages recycling of the component materials of the equipment.

Illegal disposal of the product by the user entails the application of sanctions provided by the regulations in force.

Il simbolo del cassonetto barrato riportato sull'apparecchiatura indica che il prodotto alla fine della propria vita utile deve essere raccolto separatamente dagli altri rifiuti. L'utente dovrà, pertanto, conferire l'apparecchiatura giunta a fine vita agli idonei centri di raccolta differenziata dei rifiuti elettronici ed elettrotecnici, oppure riconsegnarla al rivenditore che, a fronte di acquisto di apparecchio equivalente, è tenuto al ritiro gratuito del prodotto da smaltire. L'adeguata raccolta differenziata per l'avvio successivo dell'apparecchiatura dismessa al riciclaggio, al trattamento e allo smaltimento ambientale compatibile contribuisce ad evitare possibili effetti negativi sull'ambiente e sulla salute e favorisce il riciclo dei materiali di cui è composta l'apparecchiatura.

Lo smaltimento abusivo del prodotto da parte dell'utente comporta l'applicazione delle sanzioni previste dalla vigente normativa in materia.



NECESSARY EQUIPMENT - ATREZZATURA E D.P.I. NECESSARI

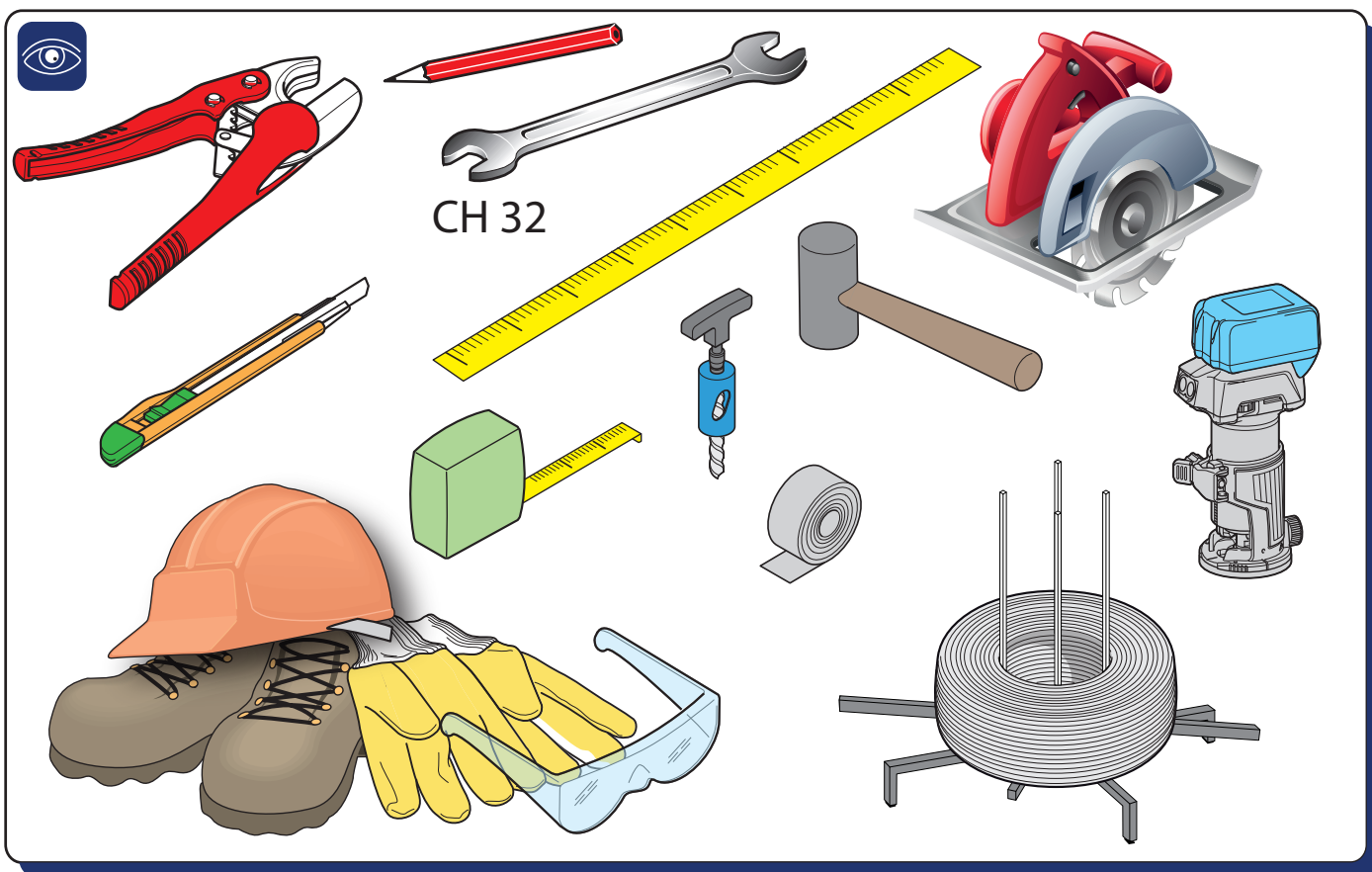



	Description	Descrizione	Pag
	SAFETY WARNINGS	AVVERTENZE PER LA SICUREZZA	3
	GENERAL WARNINGS	AVVERTENZE GENERALI	3
	DISPOSAL	SMALTIMENTO	4
	NECESSARY EQUIPMENT	ATTREZZATURA E D.P.I. NECESSARI	4
1	PRELIMINARY OPERATIONS	OPERAZIONI PRELIMINARI	6
2	DESCRIPTION	DESCRIZIONE	7
2.1	<i>Description of the Components</i>	Descrizione Componenti	8
3	PRE LAYING IMPORTANT NOTES	NOTE IMPORTANTI PRIMA DELLA POSA	9
3.1	<i>Humidity from the Substrate</i>	Umidità dal Sottofondo	9
3.2	<i>Soundproofing Mat</i>	Tappetino insonorizzante	11
3.3	<i>Conditions of the internal walls</i>	Stato delle murature interne	11
3.4	<i>Verification of the floor</i>	Verifica del solaio	12
3.5	<i>Problems caused by the substrate</i>	Problematiche riscontrate sul sottofondo	13
3.6	<i>Problems due to wrong installation</i>	Problematiche su installazioni errate	14
3.7	<i>Useful tips</i>	Consigli utili	16
4	INSTALLATION	INSTALLAZIONE	18
4.1	<i>Installation of the perimeter belt</i>	Posa della cornice perimetrale	18
4.2	<i>Installation of the e-Dry Panel</i>	Posa del pannello e-Dry	18
4.3	<i>Installation of the pipe</i>	Posa del tubo	26
4.4	<i>Installation of the weight distribution layer</i>	Posa del ripartitore di carico	30
4.5	<i>System filling</i>	Riempimento impianto	38
4.6	<i>Instruction for covering installation</i>	Indicazioni per la posa dei rivestimenti	39
4.7	<i>Installation of the skirting board</i>	Posa del battiscopa	43
4.8	<i>Advice for use</i>	Consigli di utilizzo	44



1 PRELIMINARY OPERATION - OPERAZIONI PRELIMINARI

TESTING, TRANSPORT AND UNPACKAGING

Upon receipt, check immediately that the packaging is intact: the material has left the factory in perfect working order and any damage must be notified to the carrier immediately and noted on the Delivery Sheet before it is countersigned. Within 8 days, the customer must notify the manufacturer of the extent and type of the damage noted, making a written report.

ISPEZIONE, TRASPORTO E DISIMBALLO

All'atto del ricevimento verificare immediatamente l'integrità dell'imballo: il materiale ha lasciato la fabbrica in perfetto stato, eventuali danni dovranno essere immediatamente contestati al trasportatore ed annotati sul Foglio di Consegna prima di controfirmarlo. Il Cliente, entro 8 giorni, deve avvisare il Costruttore sull'entità e la tipologia dei danni rilevati compilando un rapporto scritto.

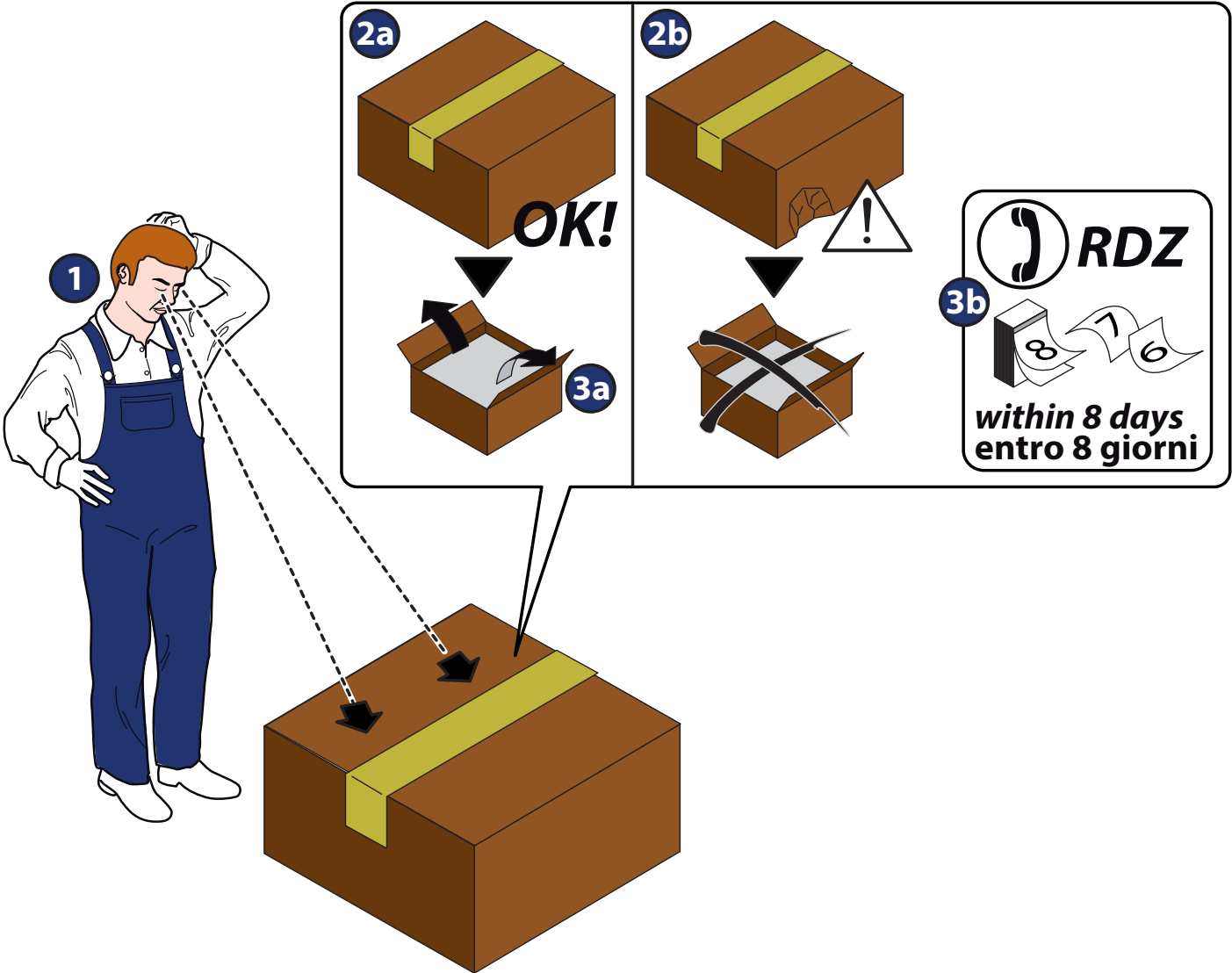

! The unit packaging must be removed with care, ensuring that the material is not damaged. The materials which make up the packaging are different: wood, cardboard, nylon etc. Store them separately and deliver them for disposal or, where appropriate, recycling, to the relevant companies, thus reducing the environmental impact.

! L'imballo dell'unità deve essere rimosso con cura evitando di arrecare possibili danni ai materiale. I materiali che costituiscono l'imballo sono di natura diversa: legno, cartone, nylon, ecc. Conservarli separatamente e consegnarli per lo smaltimento o l'eventuale riciclaggio, alle aziende preposte allo scopo e ridurne così l'impatto ambientale.



2 DESCRIPTION - DESCRIZIONE

e-Dry EVO is a dry floor heating and cooling system ideal for renovations, mezzanines and for all contemporary buildings that require very high energy efficiency.

The thickness of e-Dry Evo, in fact, is only 34 mm including both the panel and the load divider installed in place of the screed. The absence of the latter allows you to gain several centimeters in thickness, to have a flooring immediately ready for covering and makes the system operational without having to wait the time necessary for the screed to dry. The central element of the system is the e-Dry panel in sintered expanded polystyrene according to the UNI EN 13163 standard, pre-coupled with an aluminum heat-diffusing layer and equipped with grooves to house the Ø 16 pipe in PE-RT / AL / PE-RT multilayer.

The load divider, to be positioned above the radiant panel, is made up of asbestos-free, asbestos-free calcium silicate plates reinforced with cellulose fibers and inorganic additives. Thanks to the batten, these allow the creation of a single surface without interruptions, suitable for the application of the adhesive for bonding the tiles or to be covered in wood with a floating type installation.

The system is completed with the manifold, the Slim 5 perimeter band, the open curves and Isocoll 160 for gluing the panel to the substrate.

e-Dry EVO è un sistema di riscaldamento e raffreddamento a pavimento a secco ideale per ristrutturazioni, soppalchi e per tutti gli edifici contemporanei che richiedono un'altissima efficienza energetica.

Lo spessore di e-Dry Evo, infatti, è di soli 34 mm comprendendo sia il pannello che il ripartitore di carico posato in sostituzione del massetto. L'assenza di quest'ultimo permette di guadagnare parecchi centimetri di spessore, di avere una pavimentazione subito pronta per il rivestimento e rende operativo il sistema senza dover attendere il tempo necessario all'asciugatura del massetto.

Elemento centrale del sistema è il pannello e-Dry in polistirene espanso sinterizzato secondo norma UNI EN 13163, preaccoppiato con uno strato termodiffusore in alluminio e dotato di scanalature per alloggiare la tubazione Ø 16 in multistrato PE-RT/AL/PE-RT.

Il ripartitore di carico, da posizionare sopra il pannello radiante, è costituito da lastre ignifughe, esenti da amianto, in calcio silicato rinforzato con fibre di cellulosa e additivi inorganici. Grazie alla battentatura, queste permettono la realizzazione di un piano unico senza interruzioni, adatto all'applicazione dell'adesivo per l'incollaggio delle piastrelle oppure a essere rivestito in legno con una posa di tipo flottante.

Il sistema, si completa con il collettore, la fascia perimetrale Slim 5, le curve aperte e Isocoll 160 per l'incollaggio del pannello al sottofondo.

GENERAL NOTE ON DRY SYSTEMS

Dry systems by definition do not have a real screed above the plant, are therefore systems with a specific mass per square reduced compared to traditional floors and therefore can, in operation also of the flooring adopted, reverberating at the trampling.

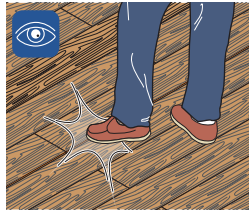

NOTA GENERALE SUI SISTEMI A SECCO

I sistemi a secco per definizione non hanno un massetto vero e proprio sopra l'impianto, sono pertanto sistemi con una massa specifica per mq ridotta rispetto ai pavimenti tradizionali e quindi possono risultare, in funzione anche del rivestimento adottato, riverberanti al calpestio.

SECTION AND DIMENSIONS

SEZIONE E INGOMBRI

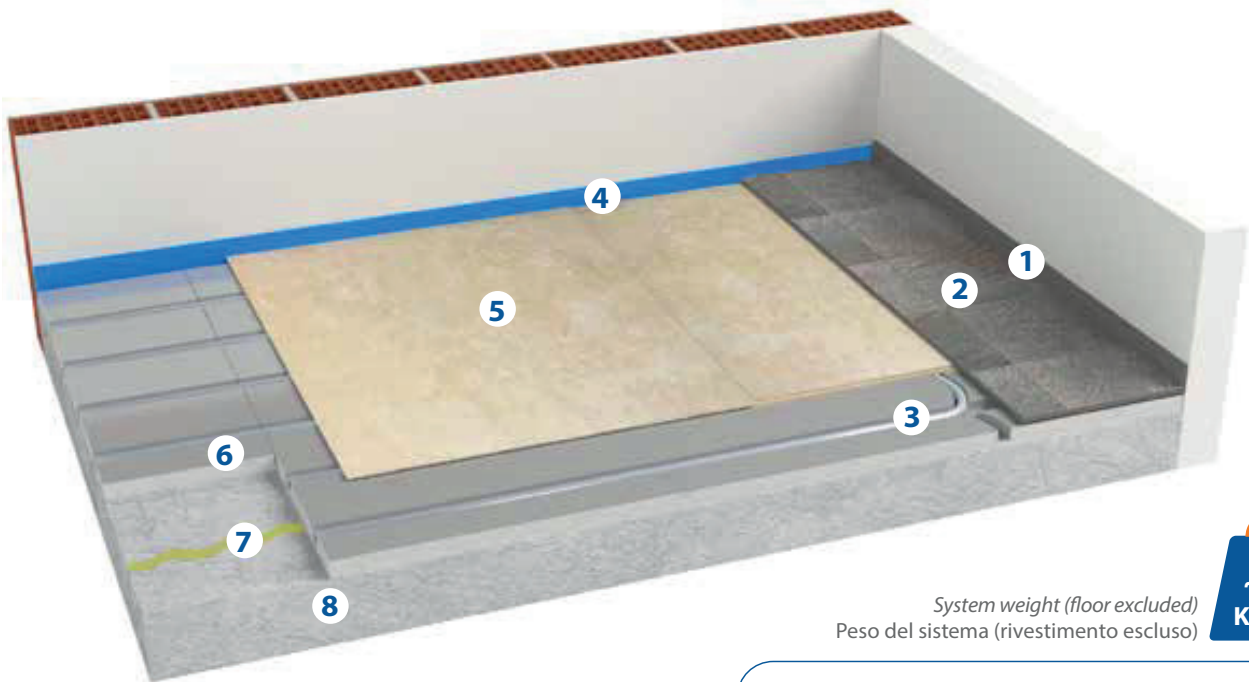

System weight (floor excluded)
Peso del sistema (rivestimento escluso)

~12
Kg/m²



- 1 Skirting board - Battiscopa
- 2 Flooring - Rivestimento pavimento
- 3 Ø 16 mm Multilayer pipe - Tubo Multistrato Ø 16 mm
- 4 Slim 5 perimeter belt - Cornice perimetrale Slim 5
- 5 Calcium silicate board - Ripartitore di carico in calcio silicato
- 6 e-Dry Panel - Pannello e-Dry
- 7 Isocoll 160 - Isocoll 160
- 8 Structural base + levelling - Solaio + getto di livellamento

Flooring - Rivestimento
Calcium silicate board - Ripart. di carico

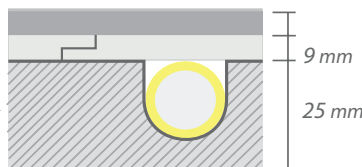
insulating thickness
Spess. isolante

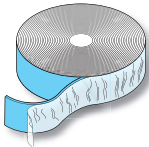
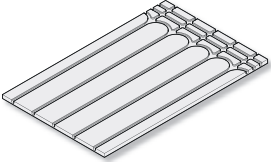
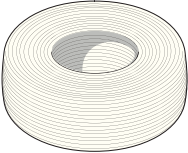
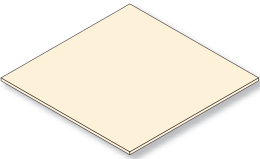

2.1 DESCRIPTION OF THE COMPONENTS - DESCRIZIONE COMPONENTI

	<p>Slim 5 Perimeter Belt</p> <p>The edge insulation Slim 5 absorbs floor expansions and acts as thermo-acoustic insulation for the walls. Thickness: 5 mm, Height: 50 mm. Roll packaging: 25 m</p>	<p>Cornice perimetrale Slim 5</p> <p>Fascia perimetrale con funzione di assorbimento delle dilatazioni del pavimento e isolamento termoacustico delle pareti. Spessore: 5 mm, Altezza: 50 mm, Confezioni rotoli: 25 m</p>
	<p>e-Dry Panel</p> <p>Grooved insulation panel made of sintered expanded polystyrene complying with UNI EN 13163. Prefabricated and applied aluminium foil on the top surface for heat emission. Special grooves to support the pipe coming from manifold. Thickness: 25 mm. Pipe spacing: 15cm. Thermal conductivity 0.032 W/(m·K). Thermal resistance 0.70 (m²·K)/W. Compressive strength 300 kPa. Size: 1200x750 mm.</p>	<p>Pannello e-Dry</p> <p>Pannello in polistirene espanso sinterizzato secondo norma UNI EN 13163 preaccoppiato con uno strato termodiffusore in alluminio dotato di scanalature per l'alloggiamento della tubazione. Spessore: 25 mm. Interasse: 15 cm. Conducibilità termica 0,032 W/(m·K). Resistenza termica 0,70 (m²·K)/W. Resistenza alla compressione 300 kPa. Dimensioni: 1200x750 mm.</p>
	<p>Comfort Multilayer Pipe Ø 16</p> <p>PE-RT Type II/Al/PE-RT Type II multilayer pipe Ø 16x2 mm according to UNI EN ISO 21003. Thickness: 2 mm Packaging: 300 m</p>	<p>Tubo multistrato comfort Ø 16</p> <p>Tubo in multistrato PE-RT/Al/PE-RT Ø 16 mm prodotto in conformità alla normativa UNI EN ISO 21003. Spessore: 2 mm Confezione: 300 m</p>
	<p>Calcium Silicate Board</p> <p>Tongue-and-groove board, thickness 9 mm, made of hydrated calcium-silicate matrix reinforced with special cellulose fibres and inorganic additives. Free from asbestos, inorganic fibres, gypsum, and other hydrated mineral matrix. Thermal conductivity 0,17 W/(m·K), compressive resistance (at 5%) 6,0 N/mm², density 950 Kg/m³. Size: 1200x1200x9 mm. Package: single</p>	<p>Ripartitore di carico in calcio silicato</p> <p>Lastra spessore 9 mm battentata, realizzata in calcio silicato idrato rinforzato con fibre di cellulosa e additivi inorganici; esente da amianto, fibre inorganiche, gesso e altre matrici minerali idrate. Conducibilità termica 0,17 W/(m·K), resistenza alla compressione al 5% 6,0 N/mm², densità 950 Kg/m³. Dimensioni: 1200x1200x9 mm. Confezione: singola</p>
	<p>Open Elbow Ø 17</p> <p>Open elbow made of plastic material. It is used to support the pipes near the manifolds vertically and to protect them from any damage.</p>	<p>Curva aperta Ø 17</p> <p>In materiale plastico, con funzione di sostenere verticalmente i tubi in prossimità dei collettori e proteggerli da eventuali urti.</p>
	<p>Isocoll 160</p> <p>One-component polyurethane adhesive. Moisture hardener with low viscosity, flexible in use. This solventless glue reacts to the moisture in the air and turns to a fine and restrained foam. Consumption: 1 bottle every 5 m² approximately.</p>	<p>Isocoll 160</p> <p>Adesivo poliuretano monocomponente adatto per incollare i pannelli al sottofondo. Esente da solvente, reagisce con l'umidità presente nell'atmosfera e resiste all'acqua, alla temperatura e all'invecchiamento. Consumo: 1 flacone ogni 5 m² circa.</p>

OPTIONAL

The e-Dry system involves gluing the panels to the substrate. It is therefore not possible to install the sheet in direct contact with the e-Dry panels.

In case it is necessary to waterproof the substrate, lay the barrier sheet and then cast a levelling screed on which the e-DRY system will be installed.



OPZIONALE

Il sistema e-Dry prevede l'incollaggio dei pannelli al sottofondo.

Non è possibile quindi installare il foglio a diretto contatto con i pannelli e-Dry

Nel caso serva impermeabilizzare il sottofondo, posare il foglio barriera e successivamente realizzare un massetto di livellamento sul quale andrà installato il sistema e-DRY.

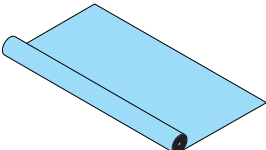
	<p>Polyethylene Sheet</p> <p>Polyethylene sheet, 0,18 mm.</p>	<p>Foglio in polietilene</p> <p>Foglio di polietilene in materiale vergine, spessore 0,18 mm.</p>
---	--	--

3 PRE LAYING IMPORTANT NOTES - NOTE IMPORTANTI PRIMA DELLA POSA

Before starting laying activities in the building site it is necessary to follow the instructions shown in the pictures below:

Prima di cominciare le operazioni di posa in cantiere è necessario seguire una serie di accorgimenti illustrati nelle figure sottostanti.

3.1 HUMIDITY FROM THE SUBSTRATE - UMIDITÀ DAL SOTTOFONDO

If humidity gets in, it is necessary to lay waterproofing material or create a crawl space as shown in the picture below.

In caso di possibilità di risalita continua di umidità è necessario prevedere l'impermeabilizzazione come da sezione sotto o la realizzazione di un vespaio areato.

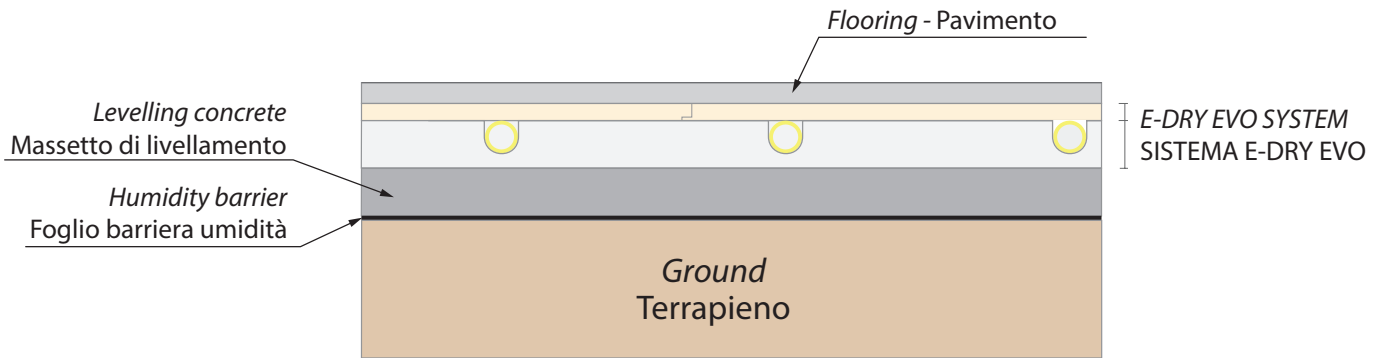

If the floor lies **directly on the ground** (without void space or insulating sheath), it is important to install a waterproof layer made of polyethylene sheets functioning as humidity barrier, minimum thickness 0,15 mm (or a similar system), to place under the panel of e-DRY system. You must use levelling concrete between the humidity barrier sheet and e-DRY system.

Se la pavimentazione si trova a **diretto contatto con il terreno** (quindi senza vuoto sanitario o guaina isolante), si procede alla posa di uno strato per l'impermeabilizzazione, costituito da un foglio in polietilene avente funzione di barriera all'umidità di spessore minimo 0,15 mm (oppure un sistema equivalente), da collocare sotto il pannello del sistema e-DRY. Tra il sistema e-DRY e la barriera umidità si rende obbligatoria la posa di un massetto di livellamento.



INSTALLATION OF HUMIDITY BARRIER

POSA BARRIERA ALL'UMIDITÀ

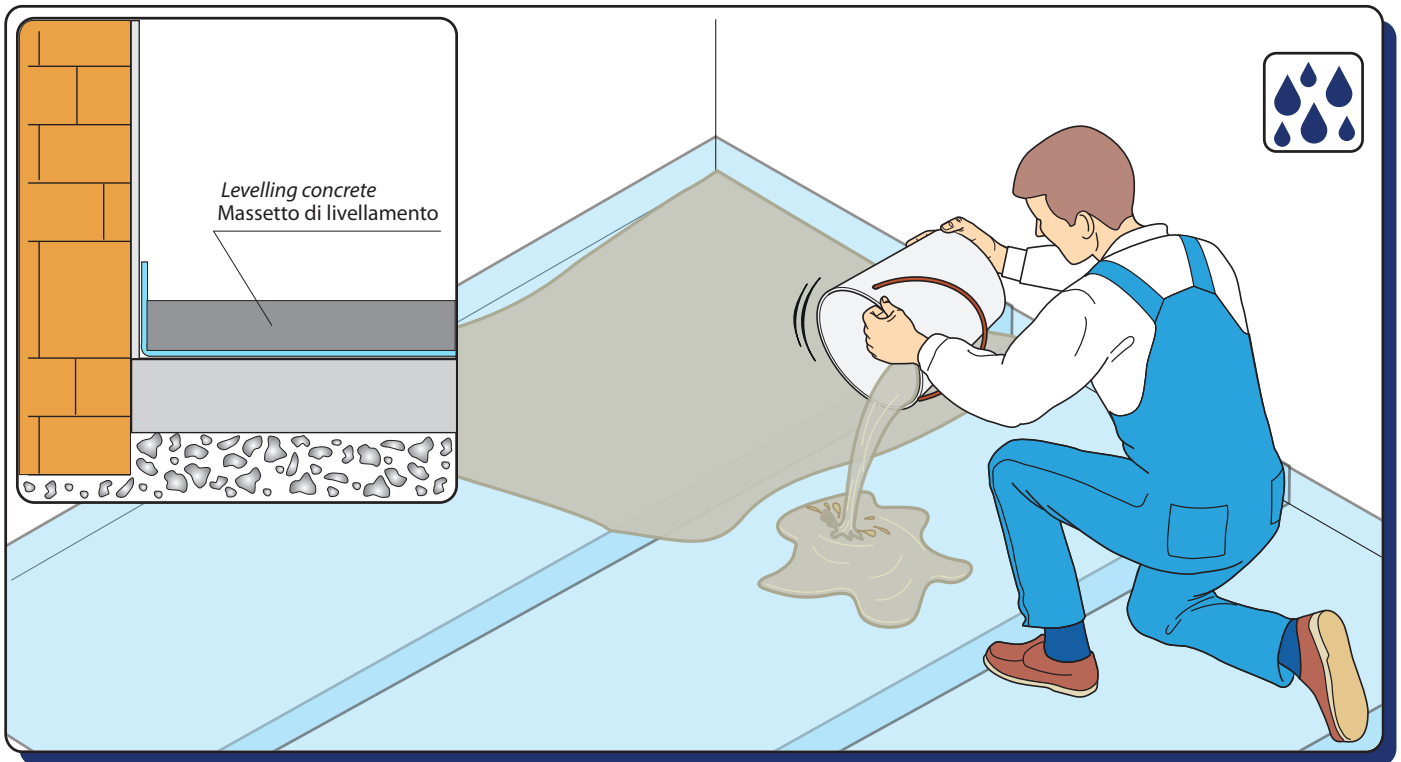
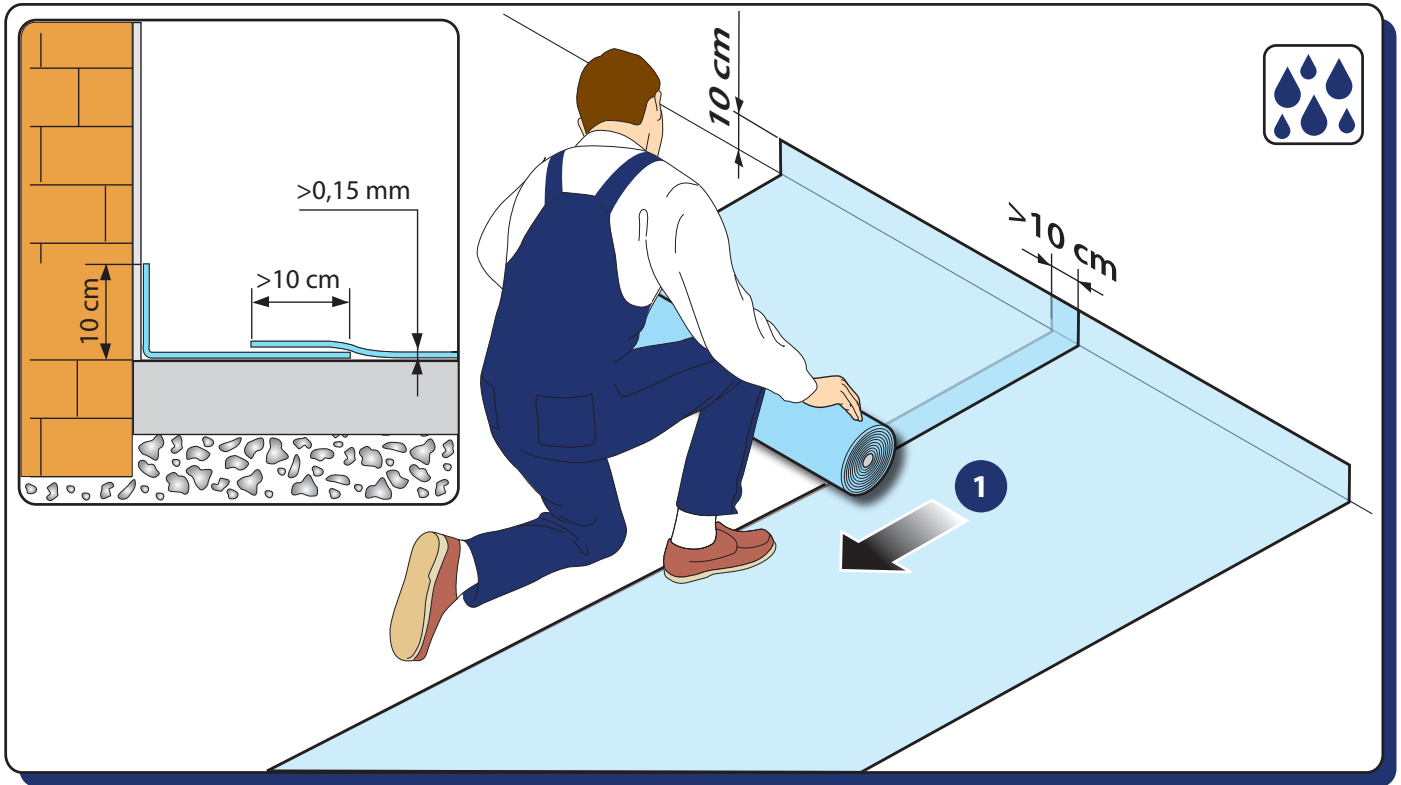

3.2 SOUNDPROOFING MAT - TAPPETINO INSONORIZZANTE

The e-Dry system involves gluing the panels to the substrate. It is therefore not possible to install any type of acoustic mat in direct contact with the e-Dry panels.

If this type of installation is necessary, lay the acoustic mat and then cast a levelling screed on which the e-DRY system will be installed.



Il sistema e-Dry prevede l'incollaggio dei pannelli al sottofondo.

Non è possibile quindi installare nessun tipo di tappetino acustico a diretto contatto con i pannelli e-Dry. Nel caso sia necessario questo tipo di installazione, posare il tappetino acustico e successivamente realizzare un massetto di livellamento sul quale andrà installato il sistema e-DRY.

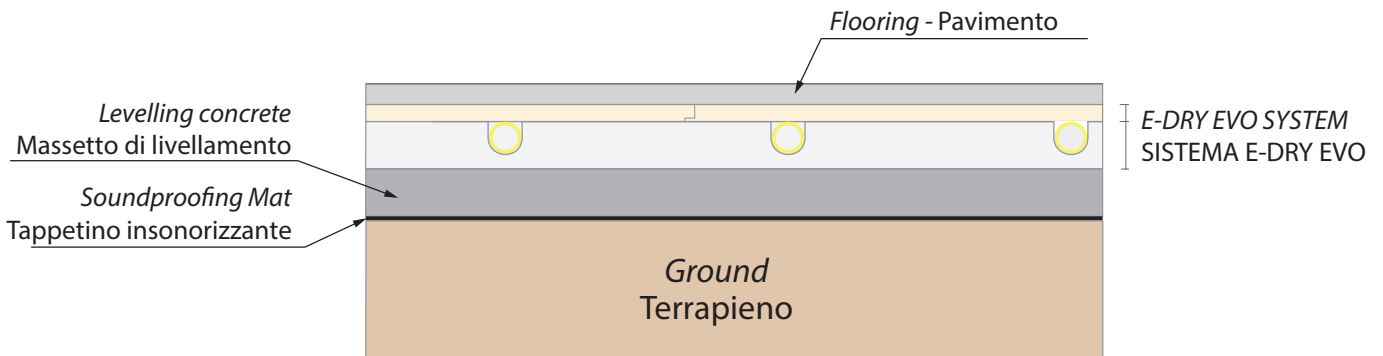

3.3 INTERNAL WALLS STATE - STATO DELLE MURATURE INTERNE

Note: before laying the panels use plaster on all the internal walls of the building where the system will be installed.

Prerogativa fondamentale prima della posa dei pannelli è la presenza dell'intonaco su tutte le murature interne dell'edificio dove sarà previsto il sistema.

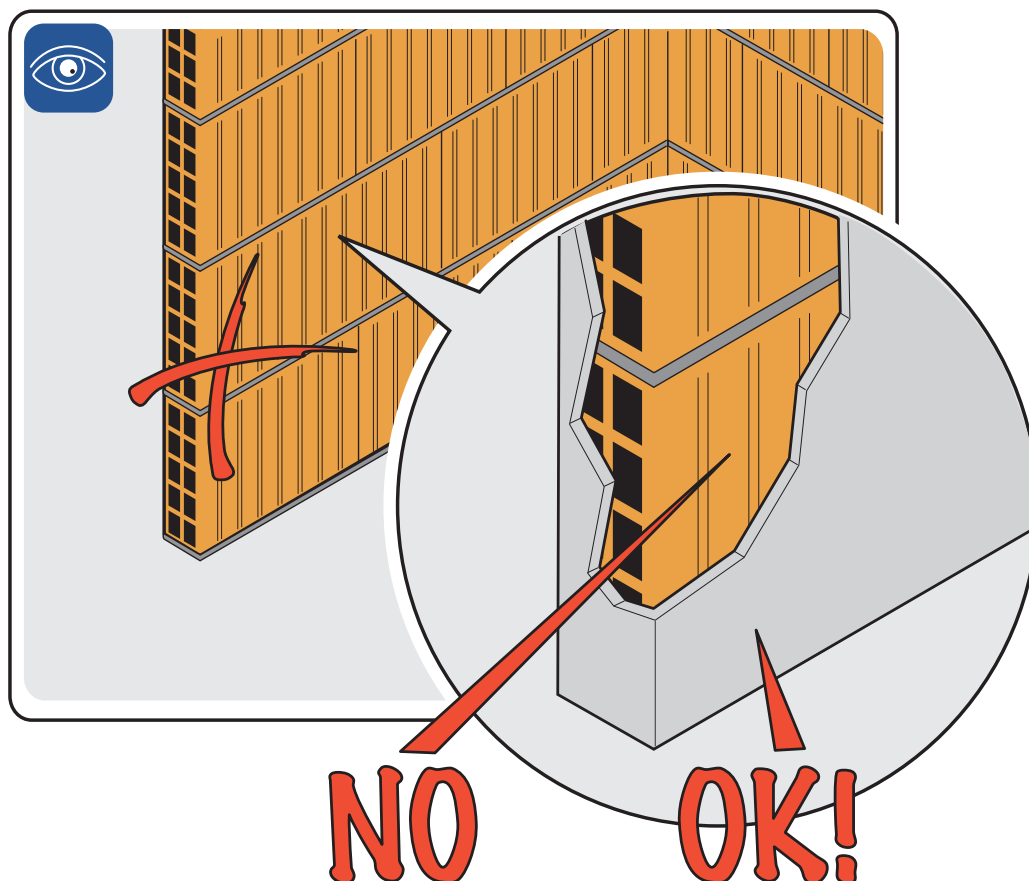



3.4 VERIFICATION OF THE FLOOR - VERIFICA DEL SOLAIO

Most important: the floor should be perfectly horizontal and smooth. Unsuitable slab may cause serious problems of breakage and cracks at surface level on future coatings.

Prerogativa fondamentale del solaio è che sia perfettamente orizzontale e liscio, essendo il sistema dry un sistema a secco una soletta non conforme alla posa, può provocare seri problemi di rotture e fessurazioni a livello superficiale sui futuri rivestimenti

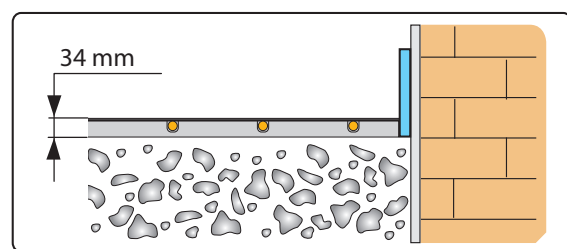
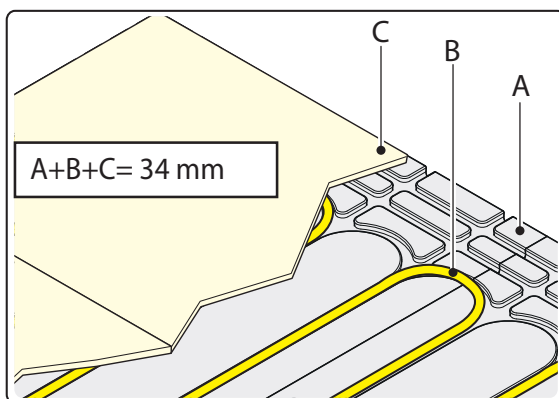
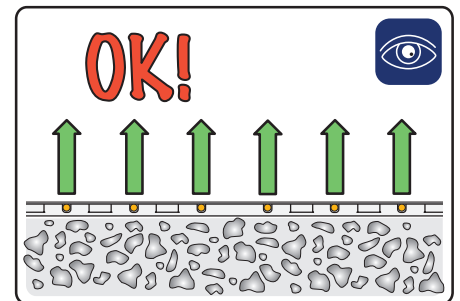
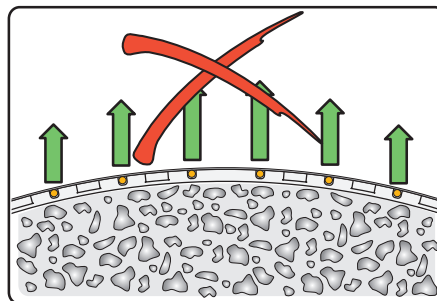
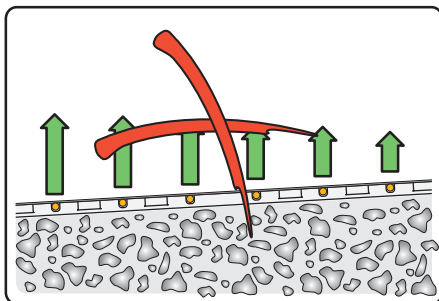
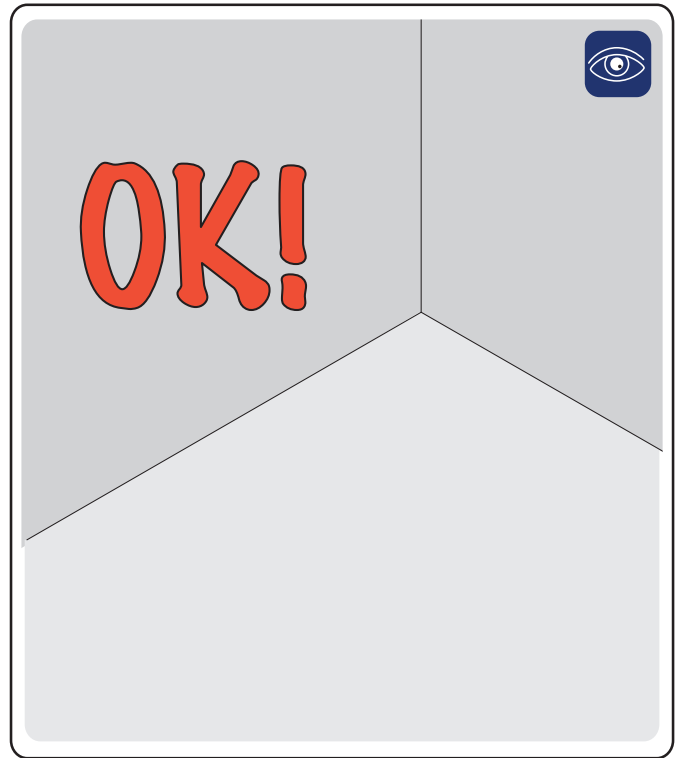

IRREGOLARE SUBSTRATE

As explained before, E-Dry system does not use concrete, therefore it is mechanically more elastic than tradition underfloor heating systems. If the substrate is irregular, different problems may arise.

SOTTOFONDO IRREGOLARE

Il sistema E-Dry, come già spiegato precedentemente, è un sistema a secco, quindi meccanicamente risulta molto più elastico di un sistema tradizionale. Se l'installazione del sistema avviene su un sottofondo irregolare, possono insorgere varie problematiche.

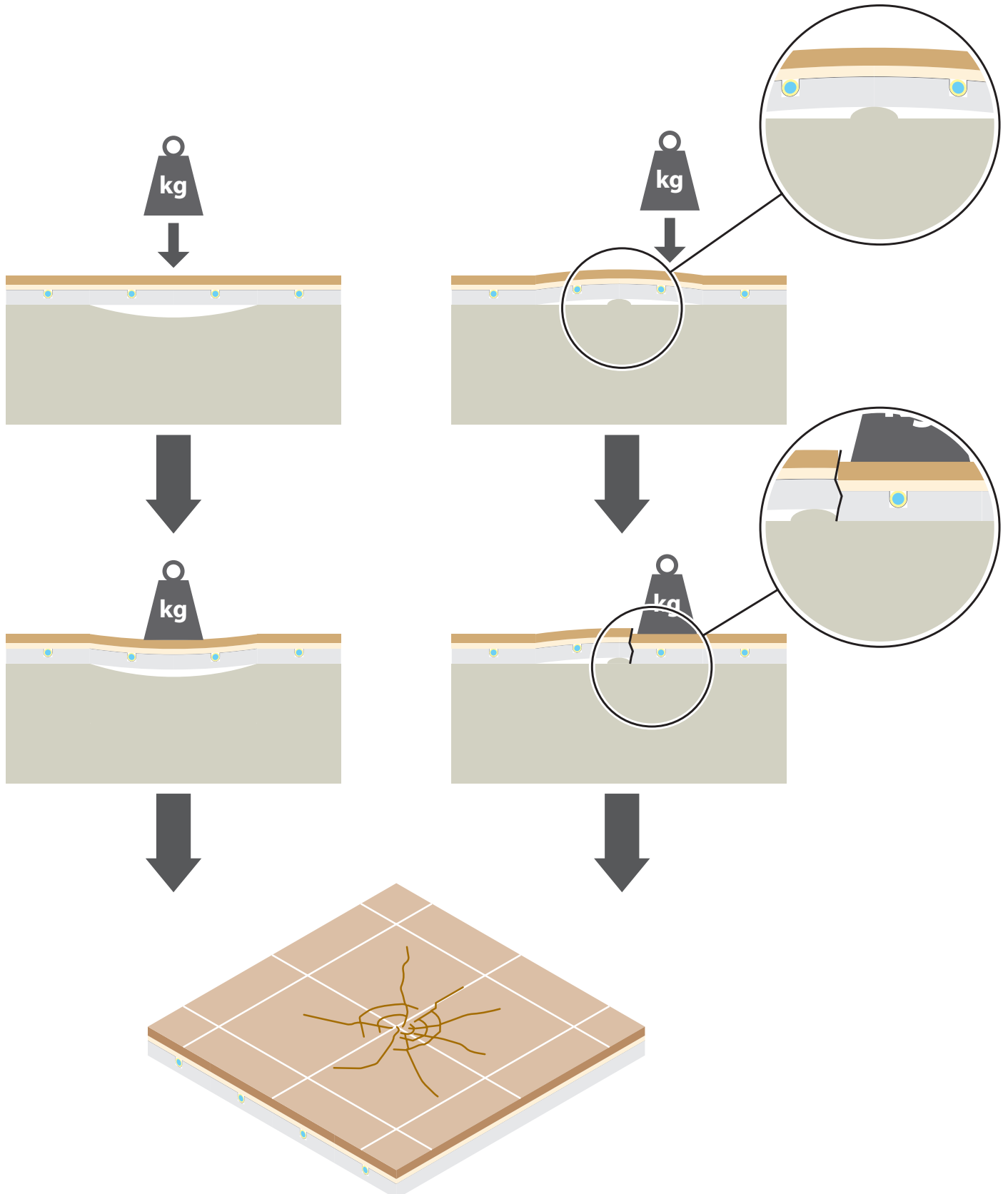



CRITICALITY ON THE EXPANSION JOINT

Another critical issue is represented by the expansion joint. This is the worst situation: in the previous case the load distribution layer diminishes the deformation of the system, but in this case the interruption in the installation drastically reduces the mechanical resistance. If the flooring is very elastic (e.g. wooden coverings) and you put something heavy on that area, the floor surface can go out of alignment. In all other cases it is likely that the floor will crack.

CRITICITA' SUL GIUNTO DI DILATAZIONE

Un altro elemento critico è rappresentato dai giunti di dilatazione. Mentre nel caso precedente il ripartitore di carico attenua la deformazione del sistema, in questo caso, mancando la continuità di posa, la resistenza meccanica si riduce notevolmente.

Con i rivestimenti elastici (es. lignei), apportando del peso, si può intravedere solo un disassamento del pavimento, ma in tutti gli altri contesti la possibilità di una rottura visibile in superficie è molto elevata.

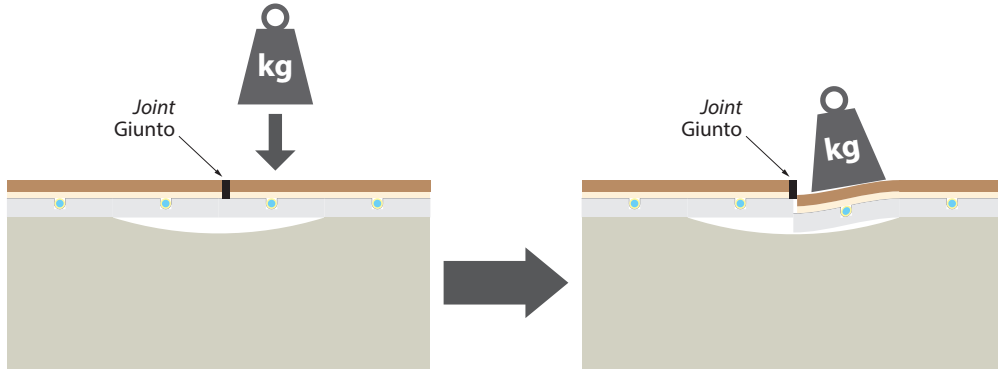

3.6 PROBLEMS DUE TO WRONG INSTALLATION - PROBLEMATICHE SU INSTALLAZIONI ERRATE

DOORSTEP

Resuming the previous situation, if the installers disregard the laying instructions and do not install the panel on the doorstep, the load distribution layer will find a large hollow which can be even 2.5 cm deep. In this case the floor will surely crack.

SOGLIE

Ripartendo dal problema precedente, se non si seguono correttamente le istruzioni del manuale di posa e non viene installato il pannello sulle soglie delle porte, la problematica relativa al ripartitore di carico non si limita solo a un piccolo avvallamento sul solaio, ma si può formare addirittura uno sbalzo di circa 2,5 cm. In questa situazione la rottura del rivestimento è praticamente assicurata.

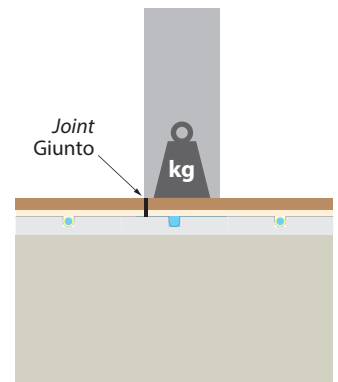
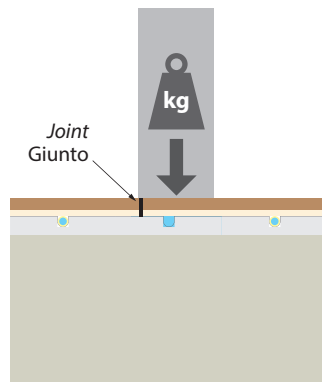
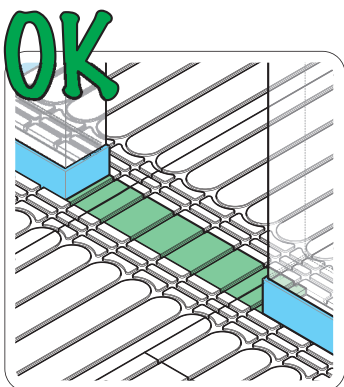
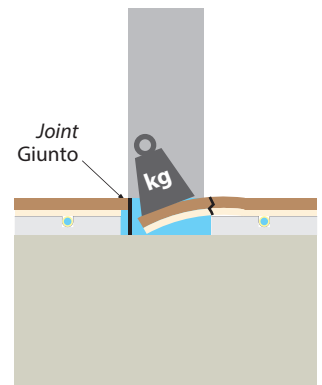
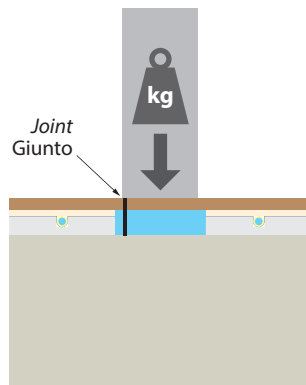
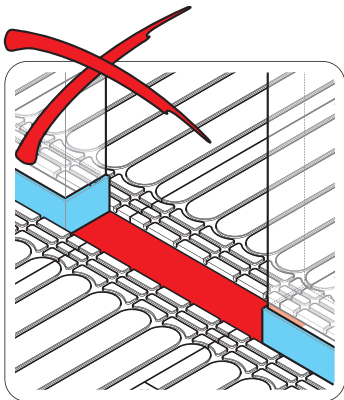



WEIGHT DISTRIBUTION LAYER

Another recurring mistake is the installation of the weight distribution layer against the insulation edge or even directly on the walls (the same remark is valid for the installation of the flooring). The thermal stress suffered by a radiant system implies that the thermal expansion of the materials shall also be taken into account. In e-Dry system with calcium silicate plates we shall pay even more attention. Let's see why:

The thermal expansion of calcium silicate is 0,009 mm/mK. If Evo-Dry system is used for both heating (with water at 40 °C) and cooling (with water at 15 °C), relevant ΔT reaches 25 K. In a 5-m wide room, we obtain the following result:

Expansion = $0,009 \times 25 \times 5 = 1,1$ mm.

If the system leans on the side walls, the expansion of 1.1 mm may raise the plates in the centre of the room by **5 cm** or more!

The boards shall be laid close to the insulation edge which will then absorb their thermal expansion.

RIPARTITORE DI CARICO

Un altro errore che può capitare facilmente in fase di installazione è quello di forzare il ripartitore di carico contro la cornice perimetrale o nei casi peggiori quello di appoggiare le lastre direttamente sulle pareti (lo stesso discorso vale per i rivestimenti).

Sollecitando termicamente un sistema radiante comporta anche che dobbiamo tenere in considerazione le dilatazioni termiche. Per il sistema e-Dry che include un ripartitore in calciosilicato le attenzioni dovranno essere ancora maggiori e ora vediamo matematicamente il perché:

Il calciosilicato ha una dilatazione termica di 0,009 mm/mK. Supponendo che il nostro sistema funzioni sia in riscaldamento (acqua 15 °C) che in raffreddamento (acqua a 40 °C), risulta un ΔT di 25 K. Ipotizzando di avere una stanza con lato 5 m il calcolo è semplice:

Dilatazione = $0,009 \times 25 \times 5 = 1,1$ mm.

Se il sistema fosse ben appoggiato alle pareti laterali, una dilatazione di 1.1 millimetri può provocare un'inarcamento del ripartitore in centro stanza di circa **5 cm**!

Le lastre vanno appoggiate leggermente sulla cornice perimetrale, poi sarà quest'ultima ad attenuare le varie dilatazioni.

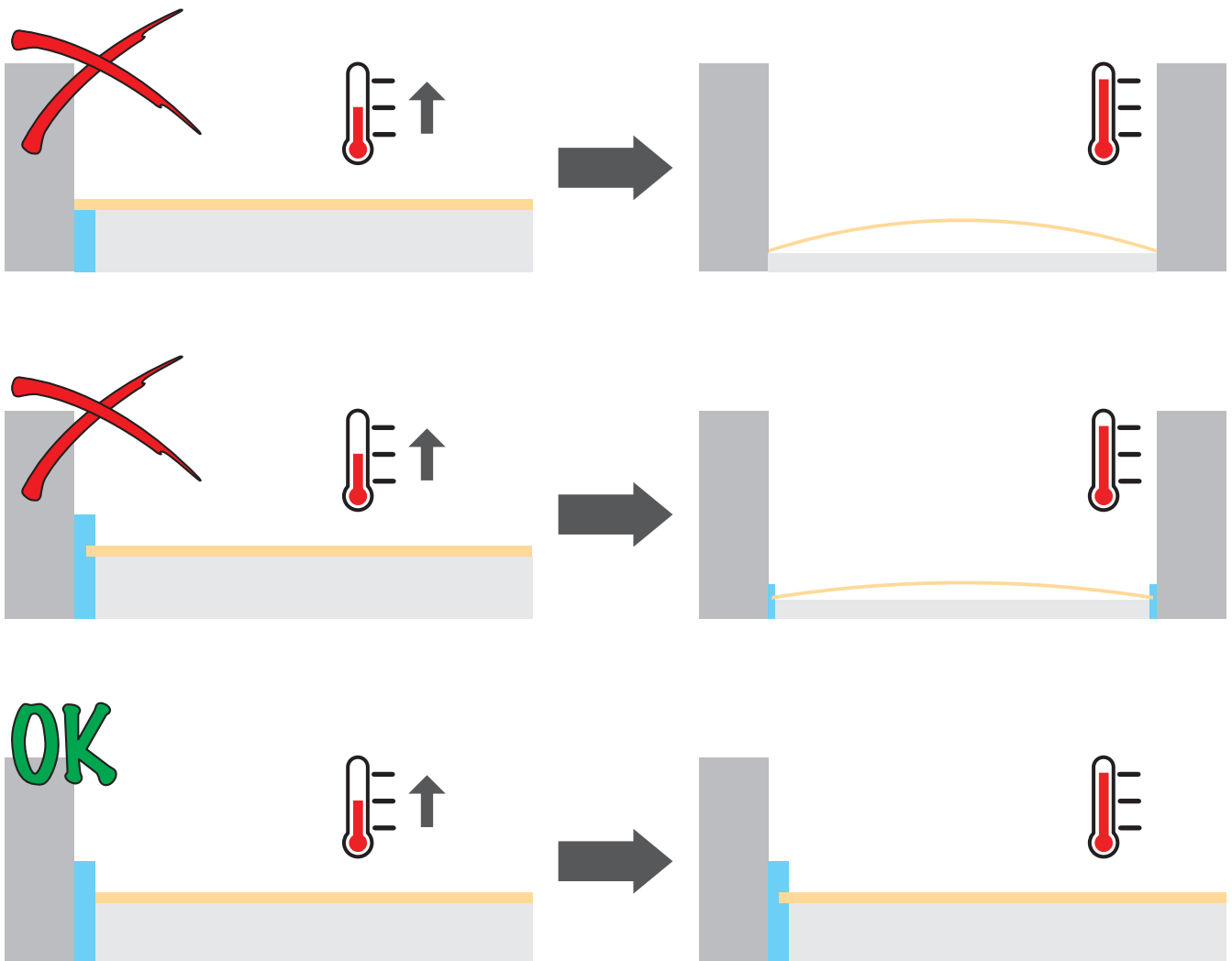



3.7 USEFUL TIPS - CONSIGLI UTILI

POSSIBILITY OF INSTALLATION

For a better practicality of laying the pipes, we advise you not to concentrate the outputs from the manifold on a single side and direction, but to divide the system equally.

POSSIBILITA' DI INSTALLAZIONE

Per una migliore praticità di messa in posa delle tubazioni, vi consigliamo di non concentrare le uscite dal collettore su un unico lato e direzione, ma di suddividere equamente l'impianto.

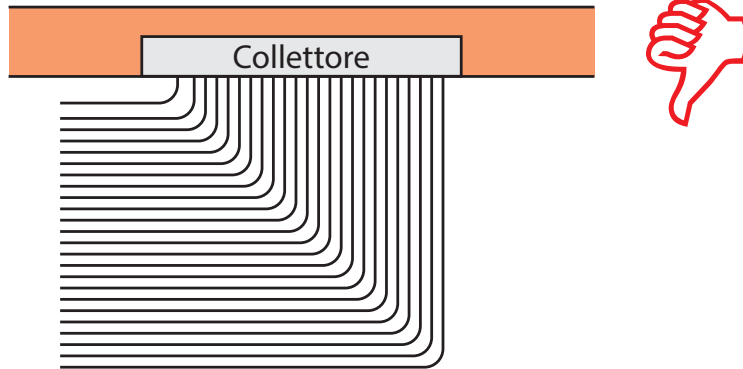

NEAR THE MANIFOLD

During the laying of the piping, near the manifold, there may be an excessive removal of the panel to facilitate the passage of the circuits. In case of stresses with overlying weights, this situation would therefore lead to a loss of mechanical resistance of the system. It is advisable to fix the pipes by applying polyurethane foam and then laying the load divider with suitable weights for a period sufficient to set

PROSSIMITÀ DEL COLLETTORE

Durante la posa della tubazione, in prossimità del collettore, ci potrebbe essere un'eccessiva rimozione di pannello per agevolare il passaggio dei circuiti. In caso di sollecitazioni con pesi sovrastanti questa situazione comporterebbe quindi una perdita di resistenza meccanica del sistema. Si consiglia di fissare le tubazioni applicando schiuma poliuretana e posando successivamente il ripartitore di carico con adeguati pesi per un periodo sufficiente alla presa.

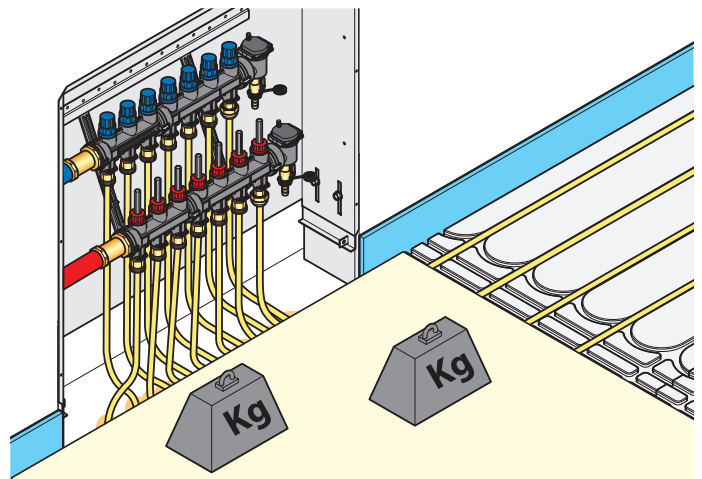
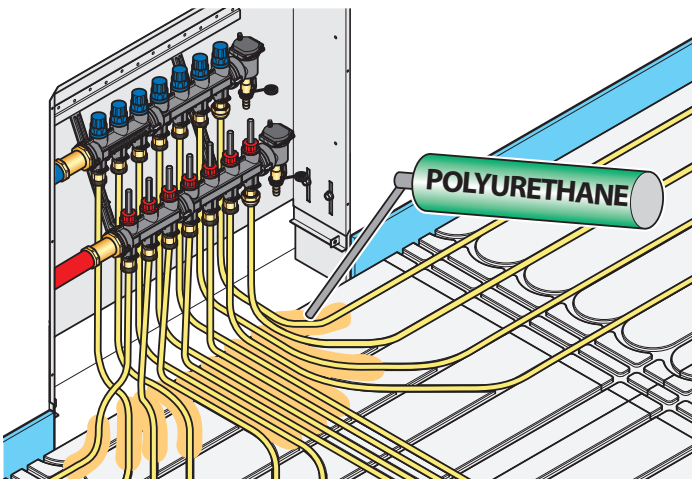



In the event that the panel is not sufficient to contain the grooves for all the pipes, we advise you not to provide the e-Dry panel in this area, but to prepare a leveling screed of about 0.50 m² where you can then lay the flooring.

Nel caso in cui il pannello non sia sufficiente a contenere le fresate per tutte le tubazioni, vi consigliamo di non prevedere in quest'area il pannello e-Dry, ma di predisporre un massetto di livellamento di circa 0,50 m² dove poi poter posare il rivestimento.

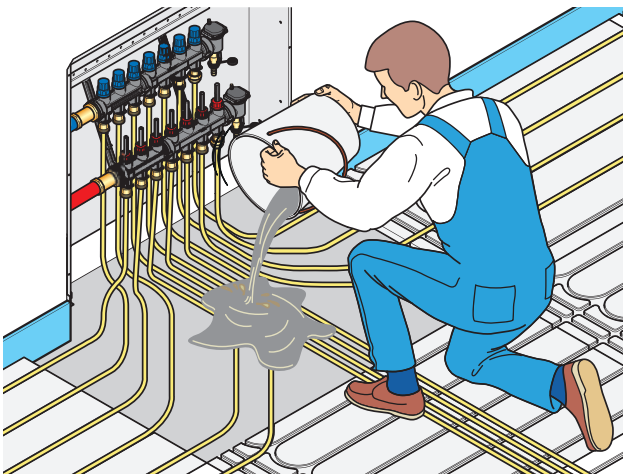
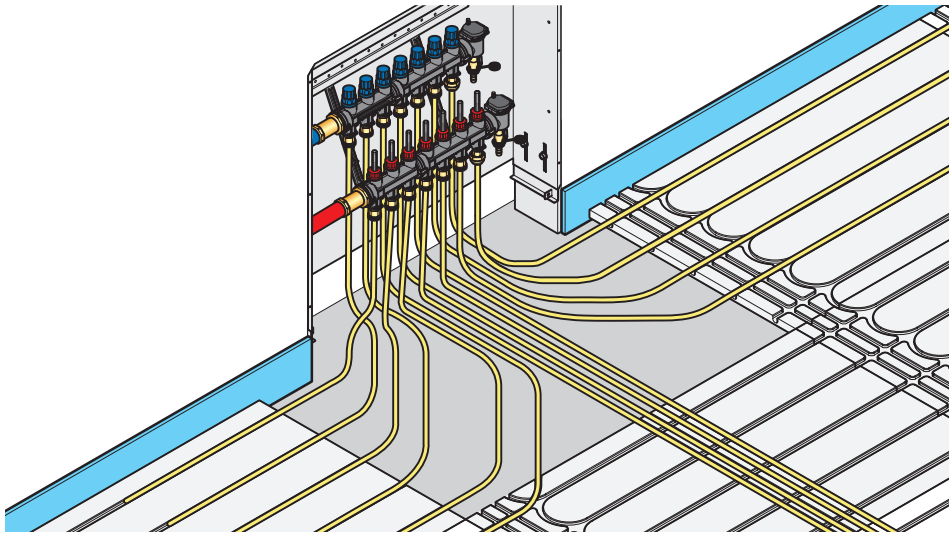

ADDITIONAL INSULATING LAYER

If you are not using e-Dry system for its minimum construction height but rather for its low inertness and fast heating up time, when it is necessary you can add another insulating layer under the system. The Dry-Tech panel and the insulating layer shall be stuck together. Furthermore, this additional panel shall be stuck on the substrate, and it shall be characterized by compressive stress **higher than 500 kPa** according to EN 826.

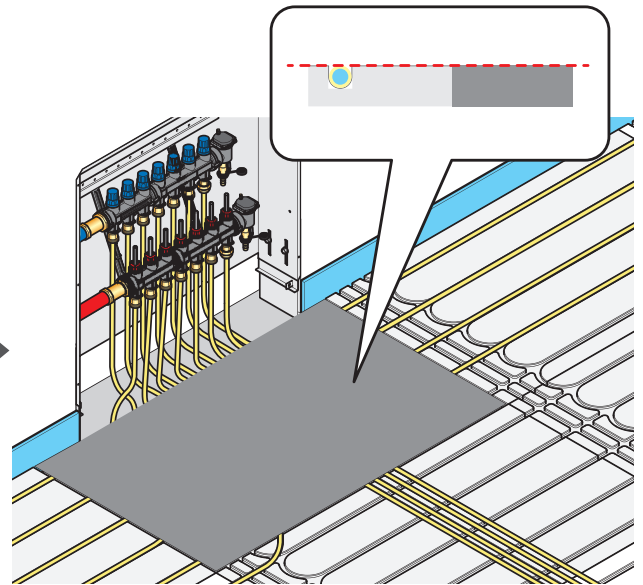

ULTERIORE STRATO ISOLANTE

Se si utilizza il sistema e-Dry non come impianto a basso spessore ma per la sua velocità di messa a regime, qualora ce ne fosse la necessità, è possibile aggiungere un ulteriore strato isolante al di sotto del sistema stesso. Entrambi i pannelli dovranno essere opportunamente incollati tra loro, e il pannello isolante aggiuntivo dovrà essere a sua volta incollato al sottofondo. È fondamentale che questo strato isolante presenti una resistenza a compressione secondo EN 826 di **almeno 500 kPa**.

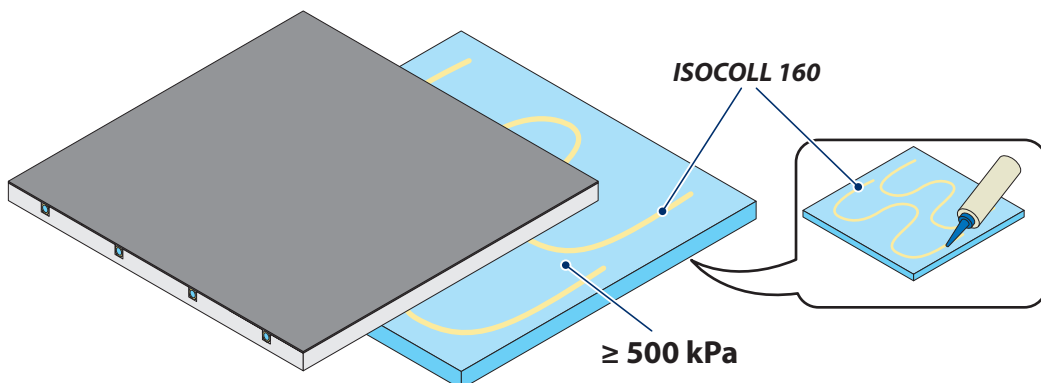



4 INSTALLATION - INSTALLAZIONE

4.1 INSTALLATION OF THE PERIMETREL BELT - POSA DELLA CORNICE PERIMETRALE

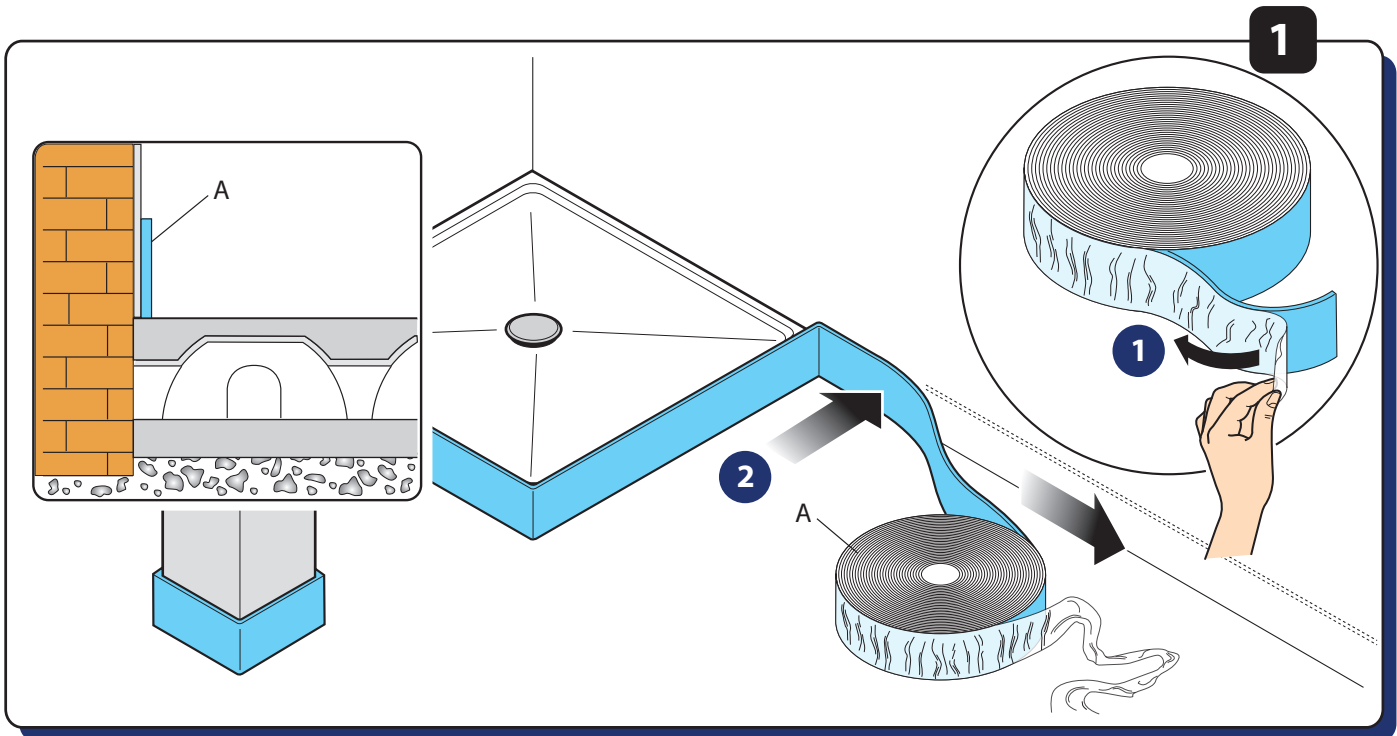

4.2 INSTALLATION OF THE E-DRY PANEL - POSA DEL PANNELLO E-DRY

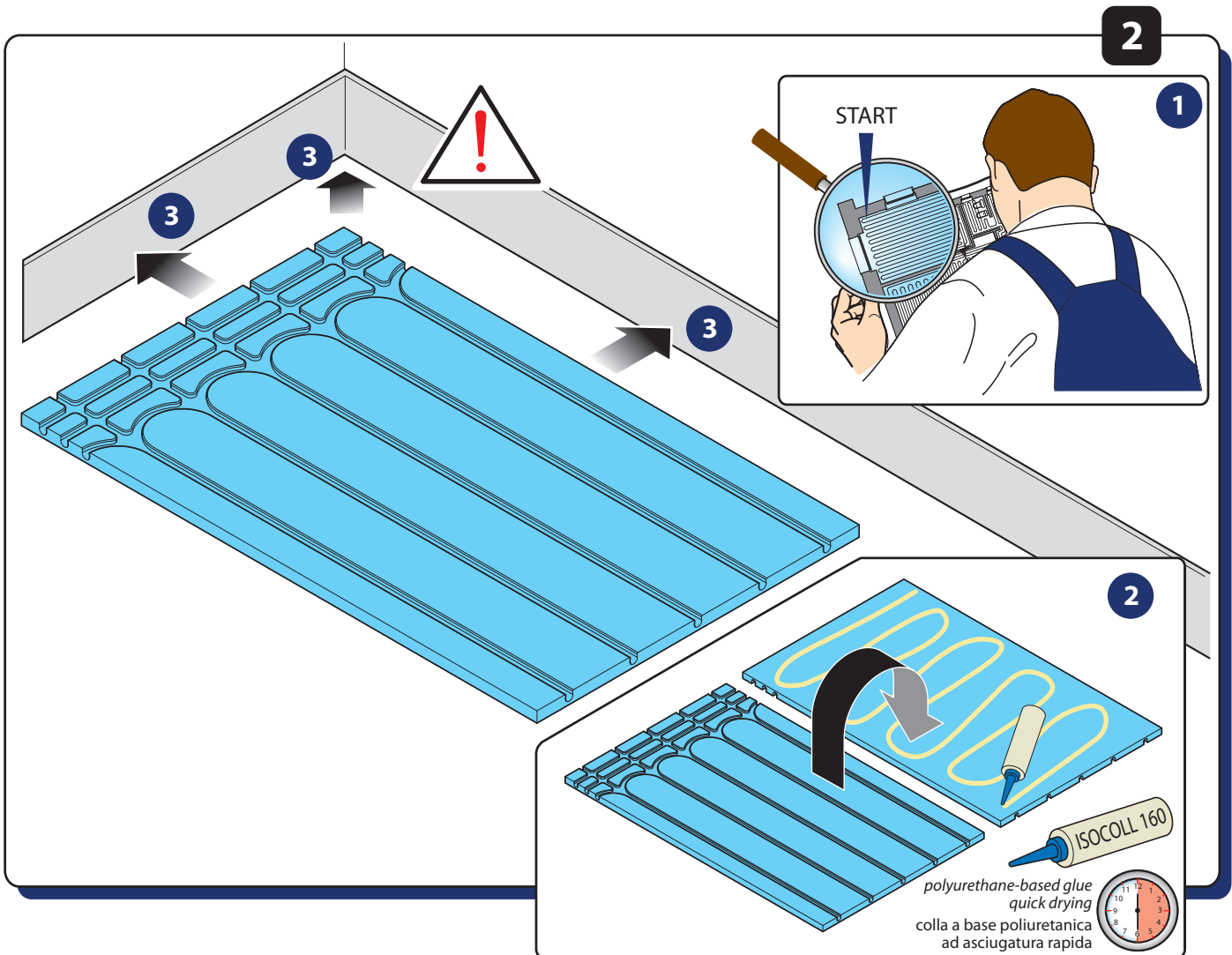



3

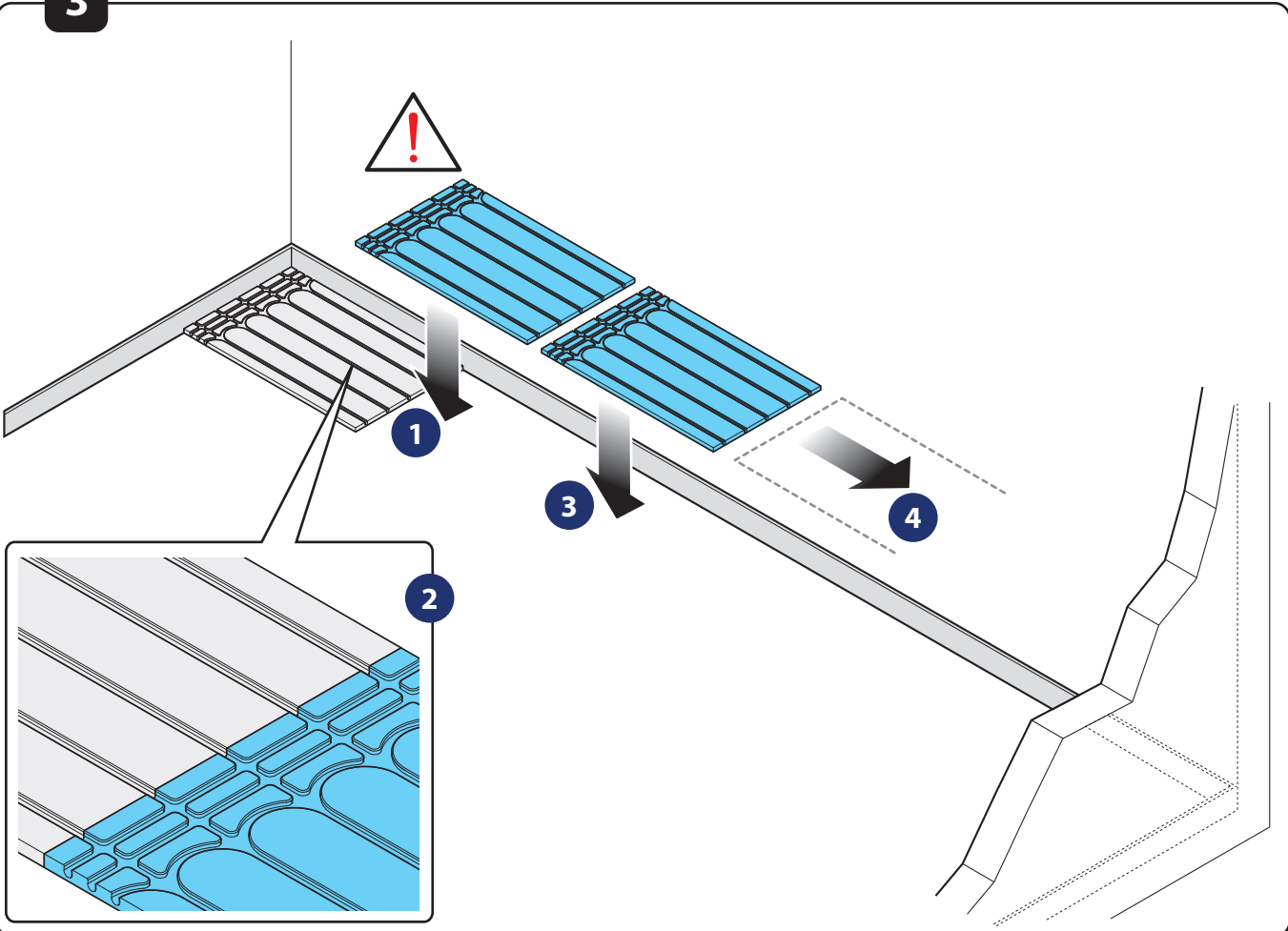

4

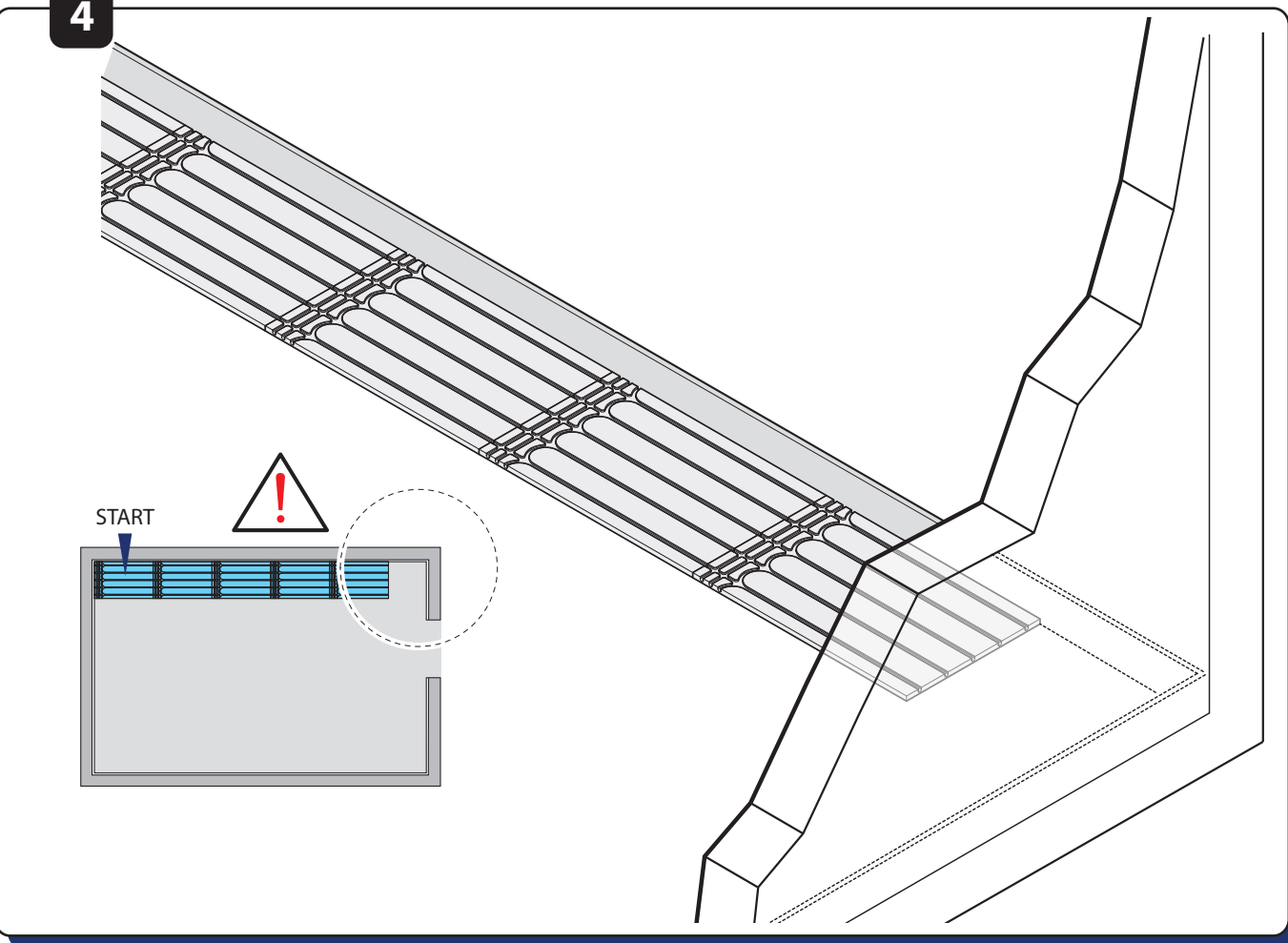



5

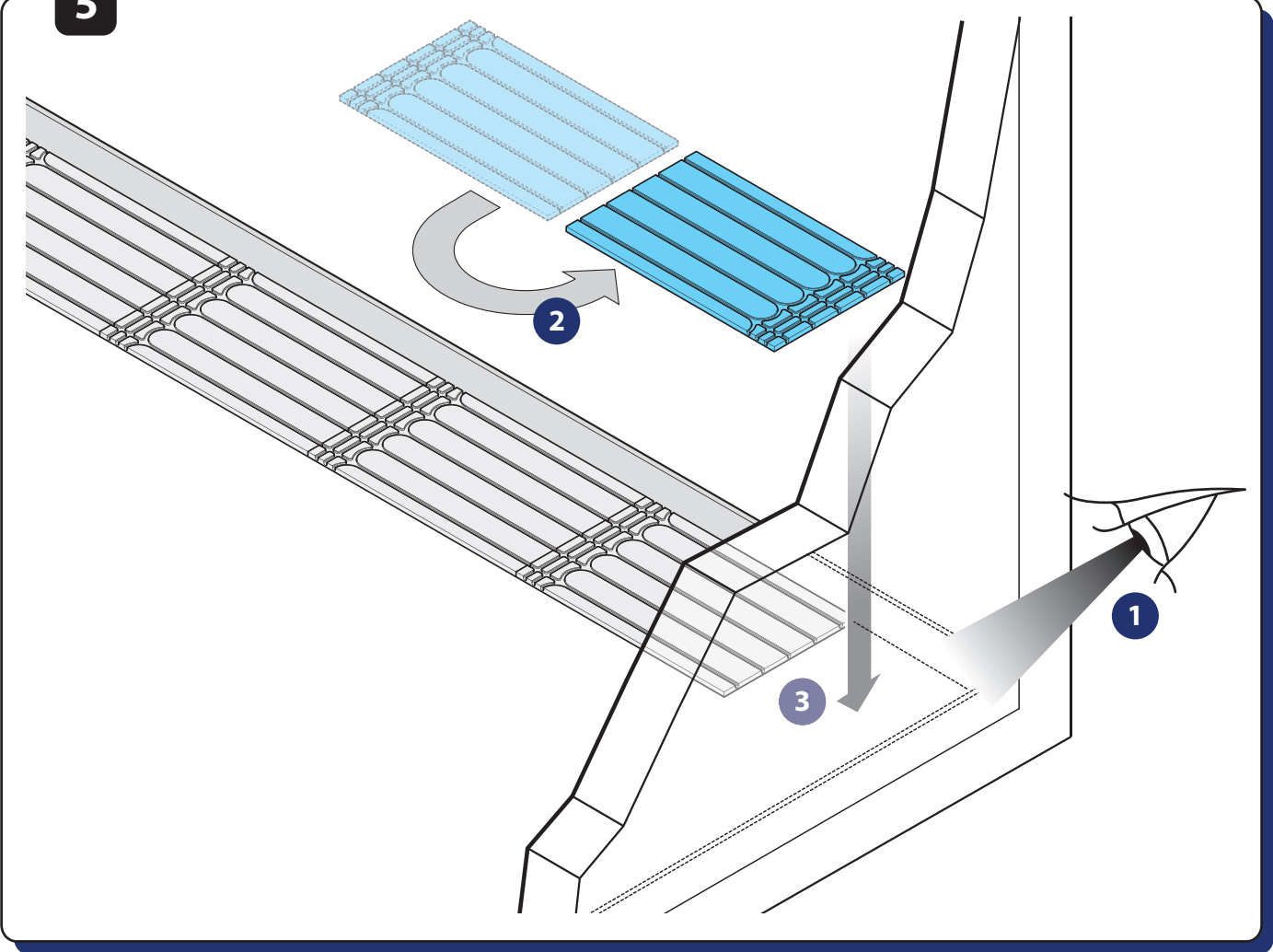

6

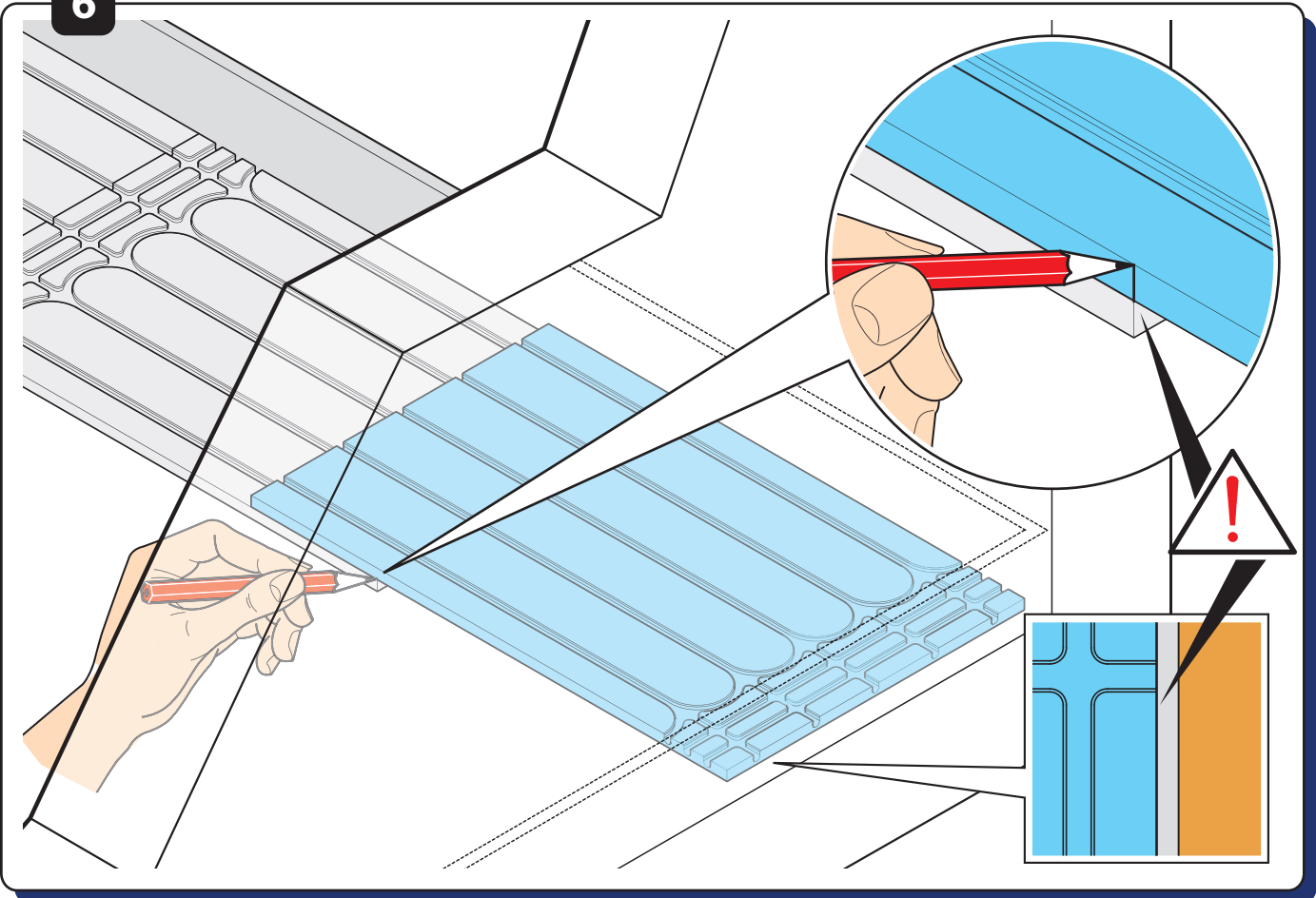



7

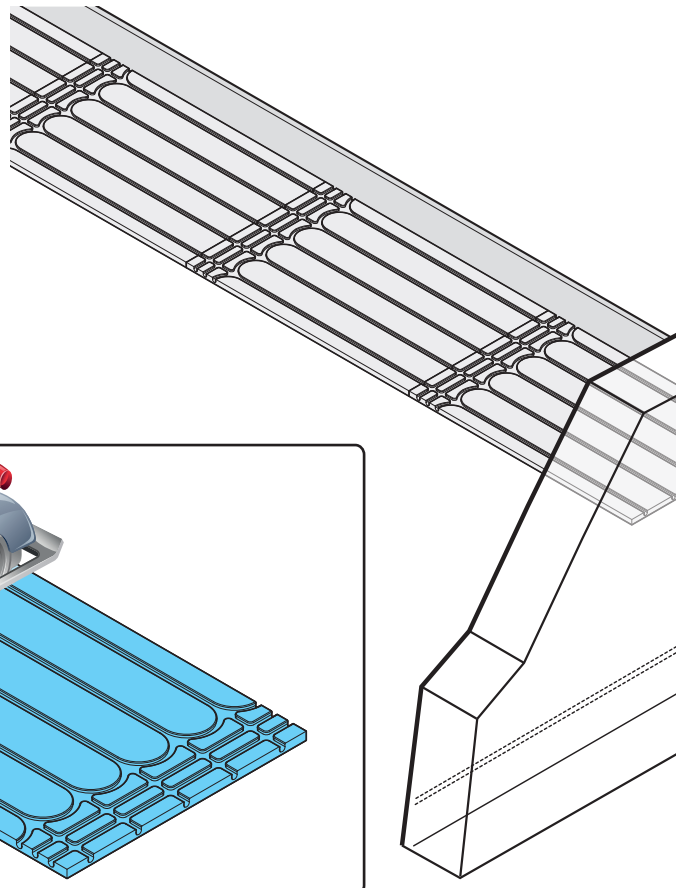
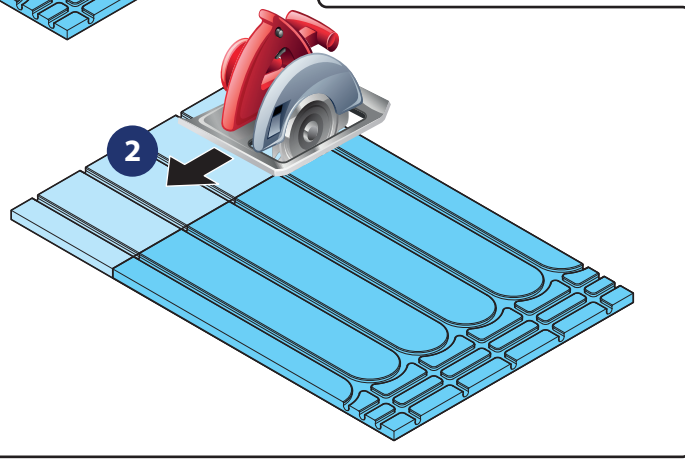
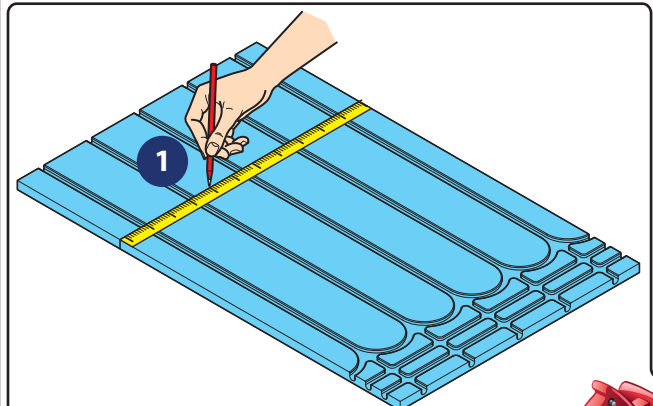

8

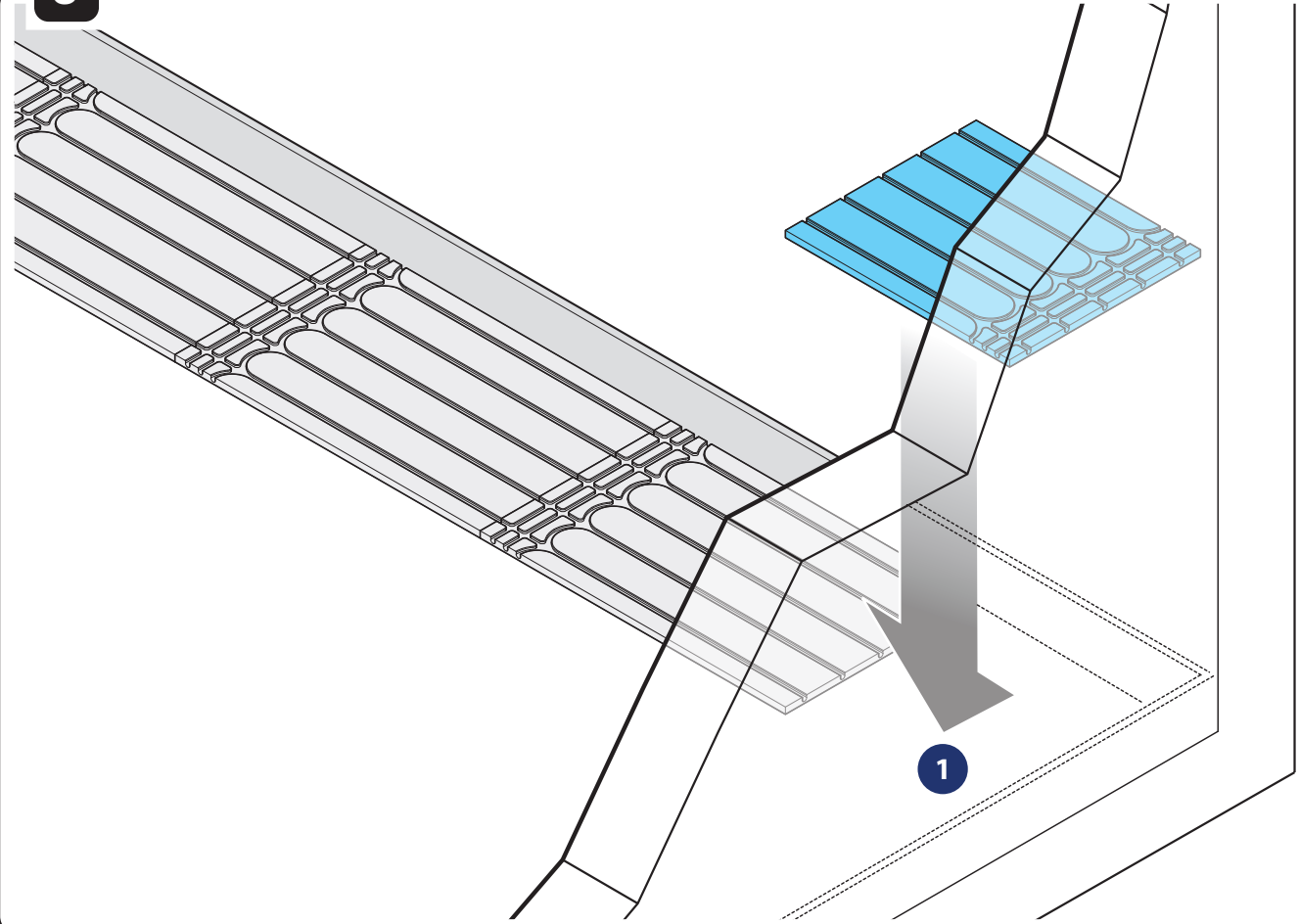



9

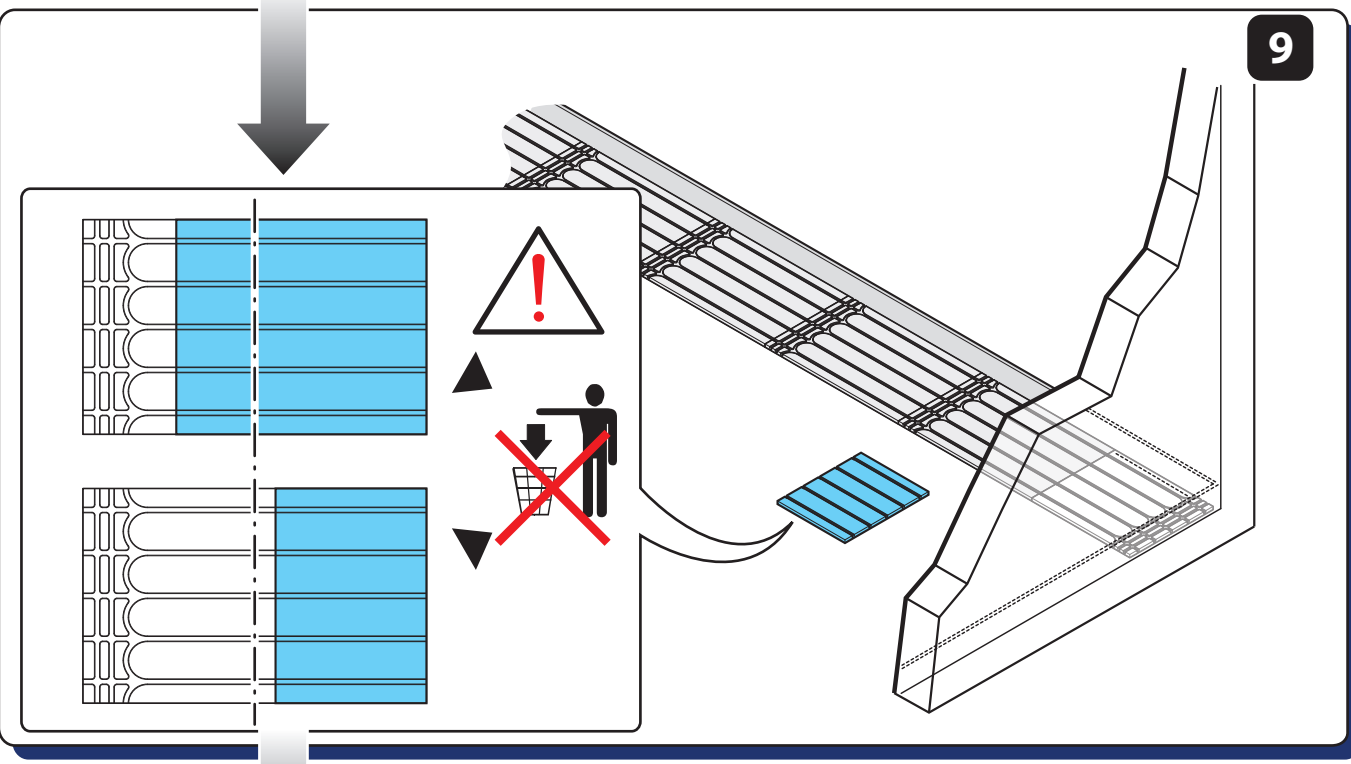

10

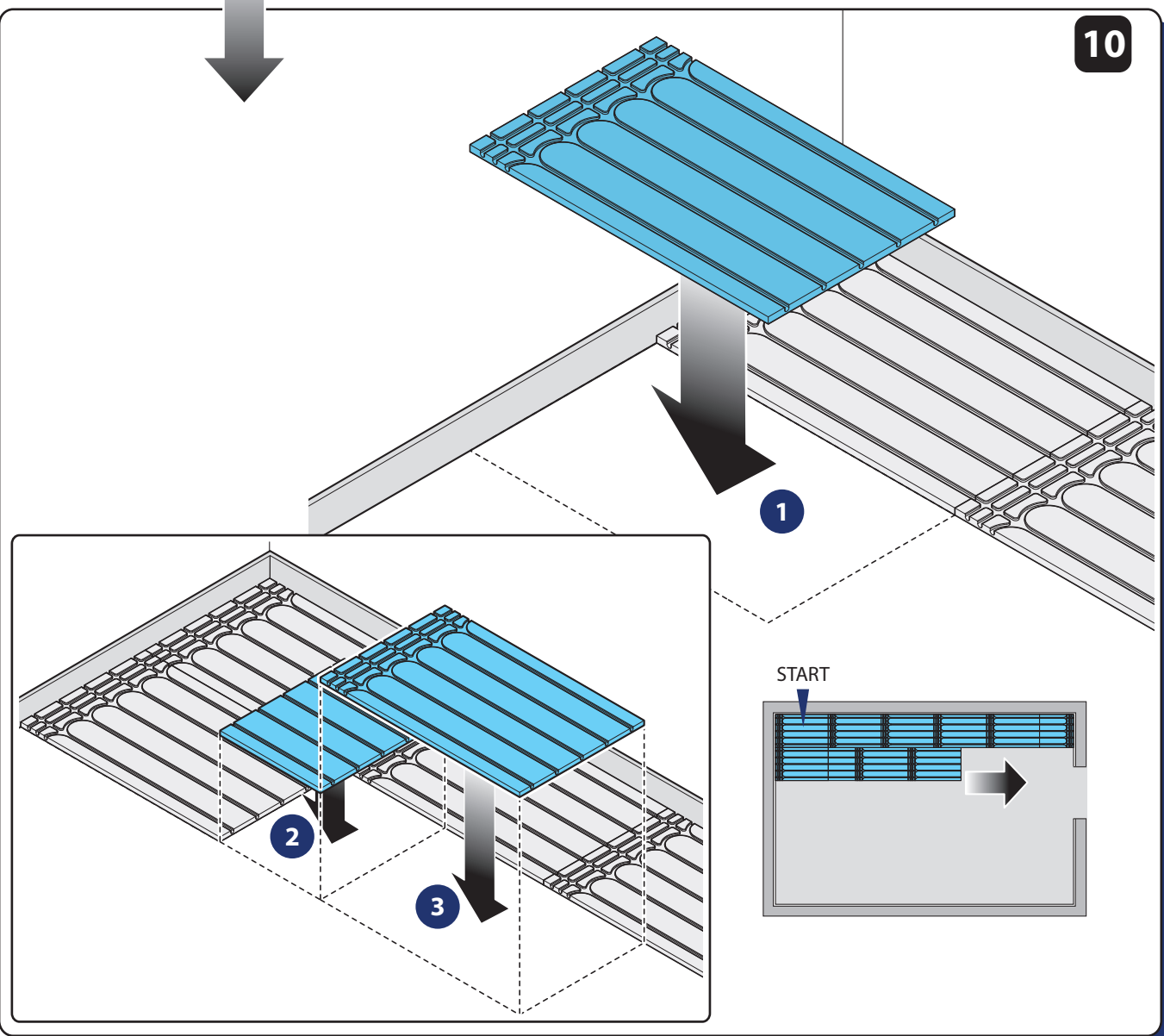



11

START

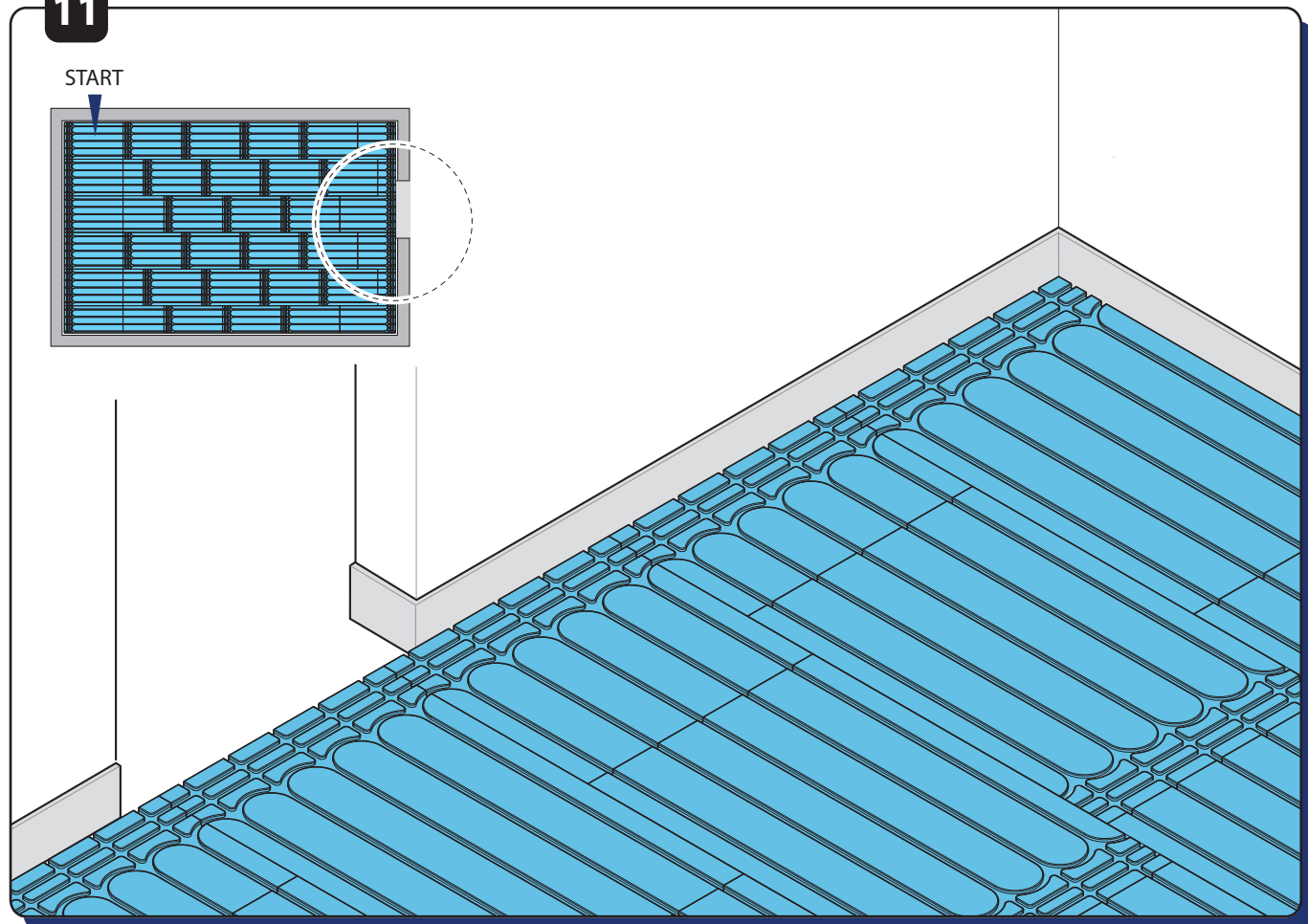
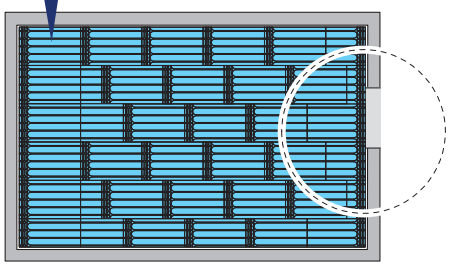

12A

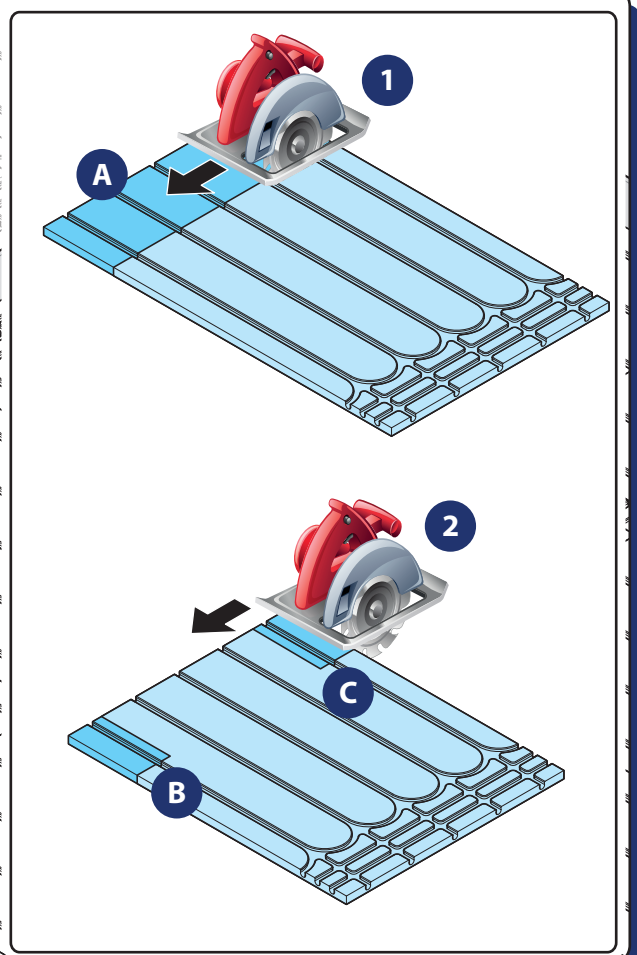
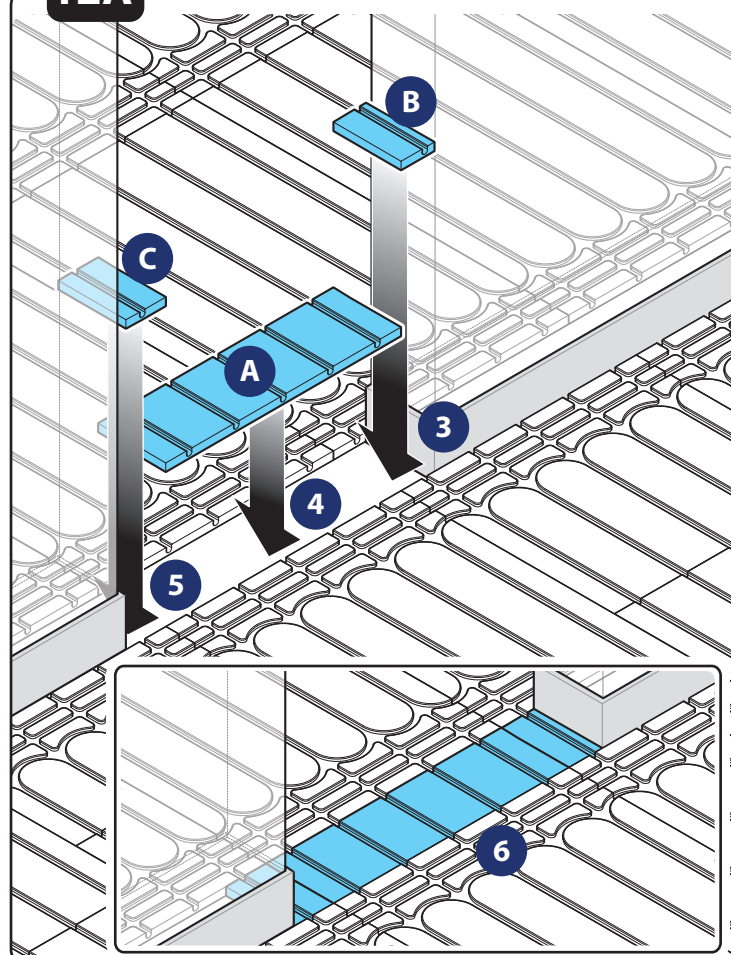



13A

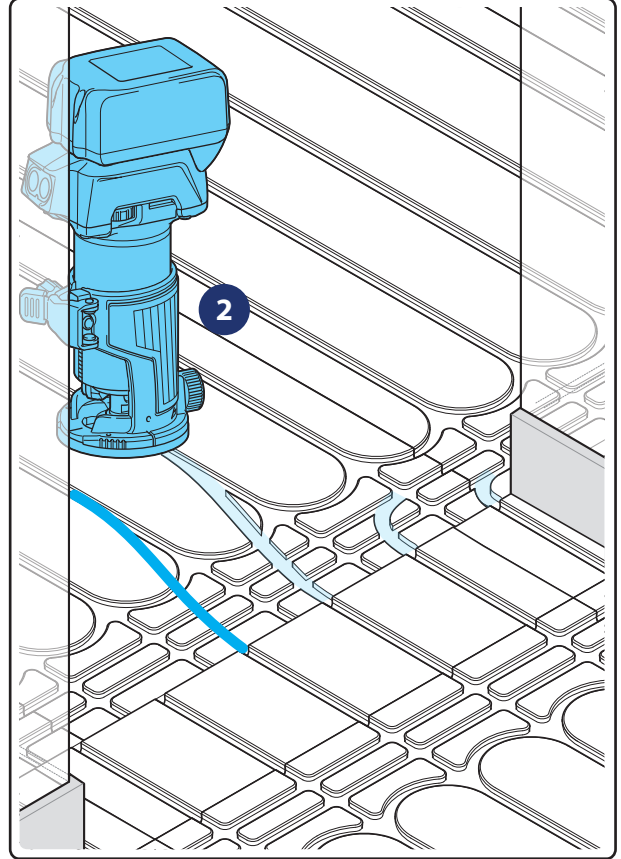
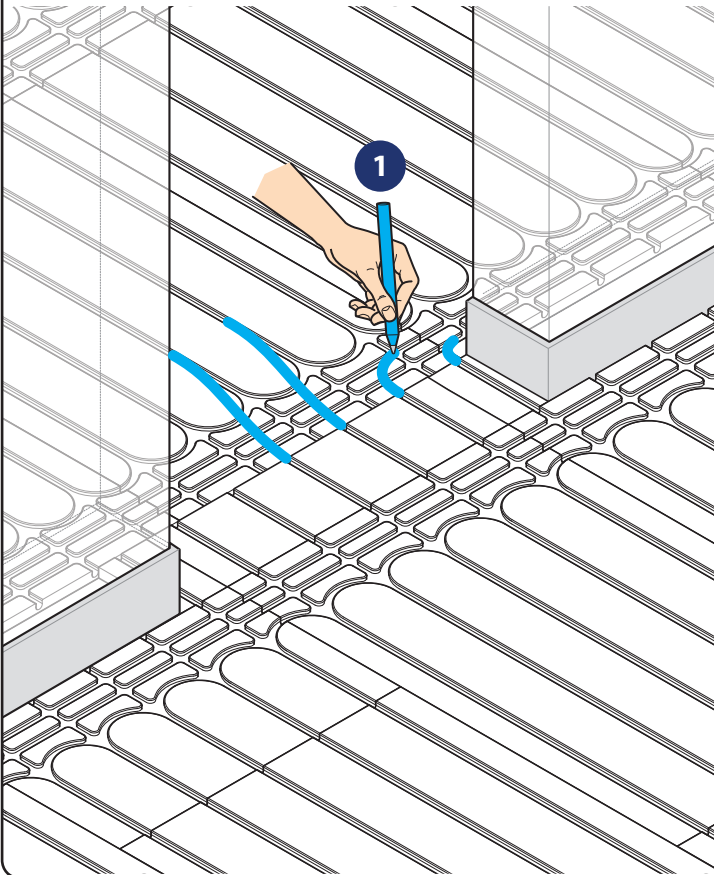

12B

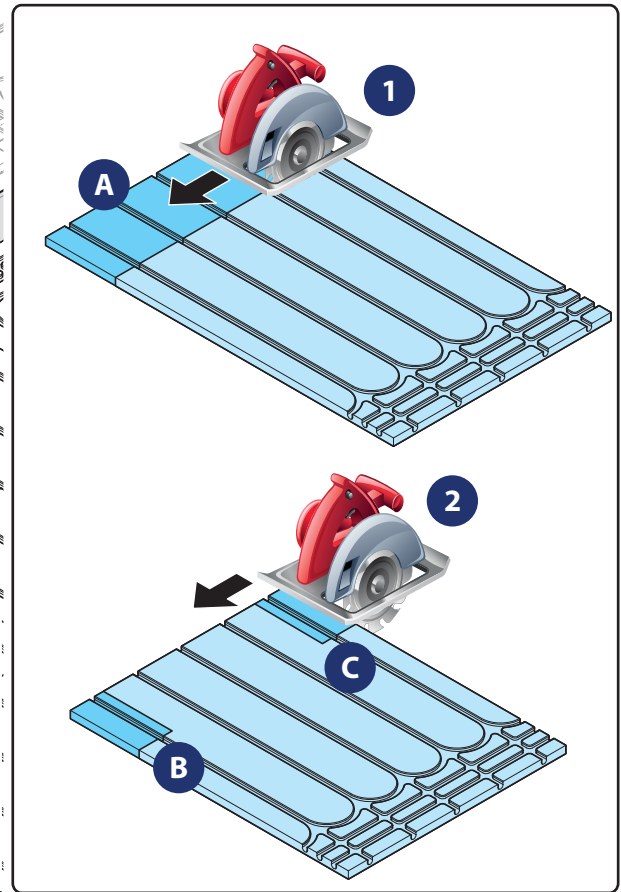
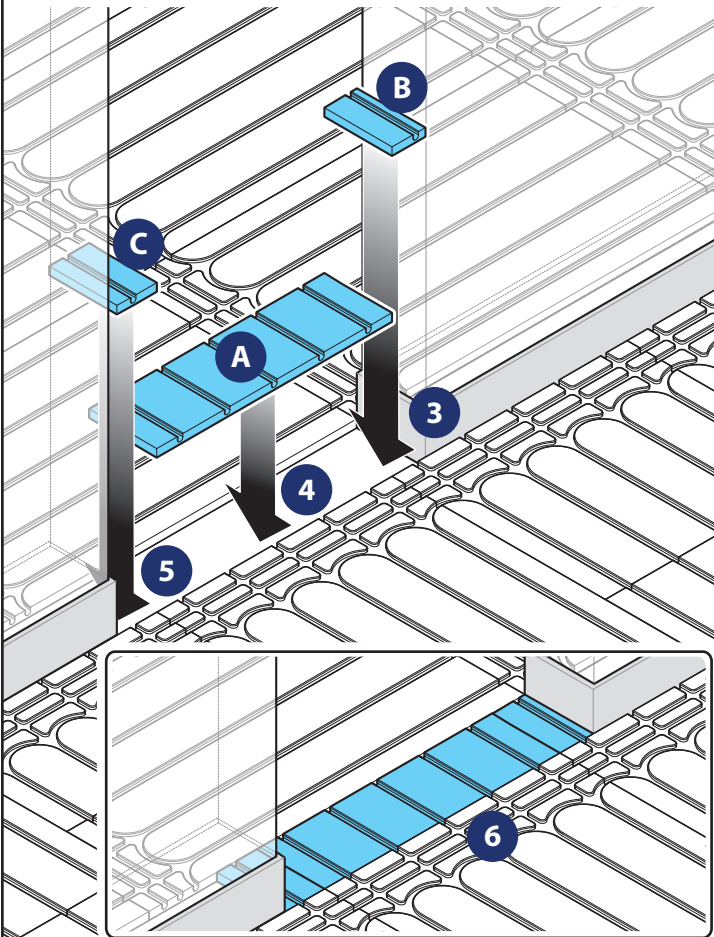



13B

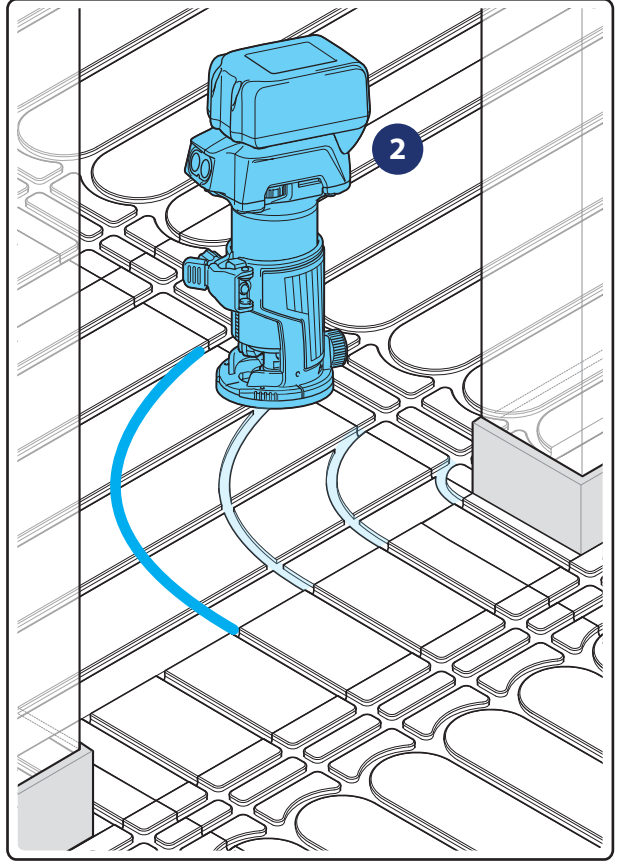
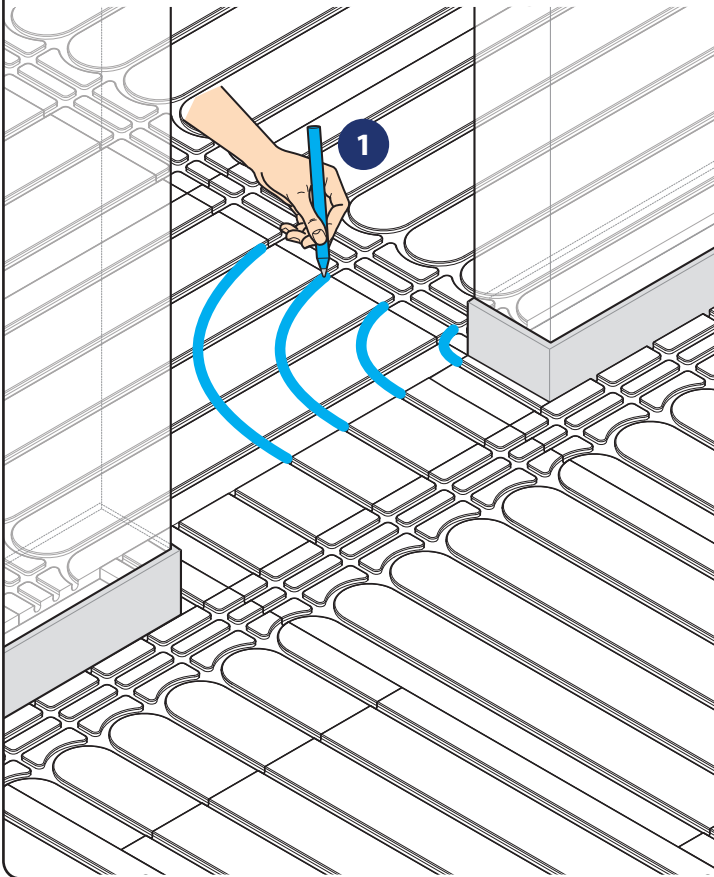

14

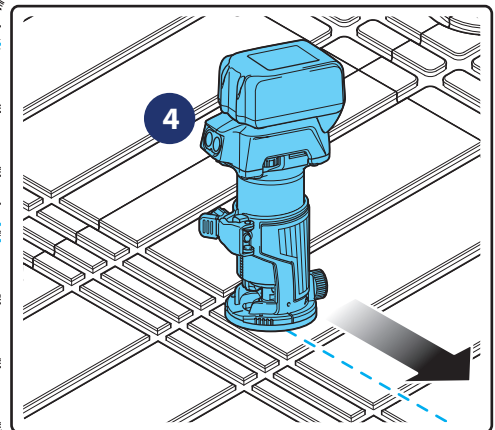
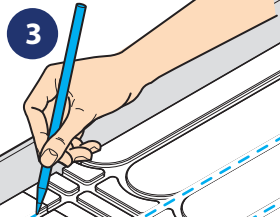
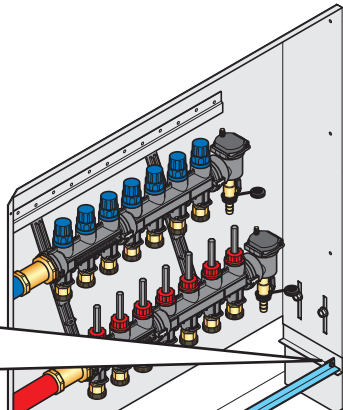
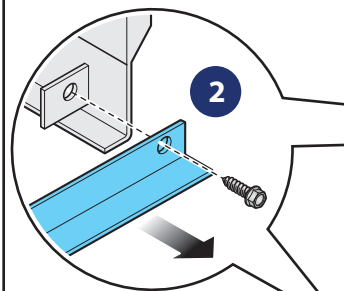
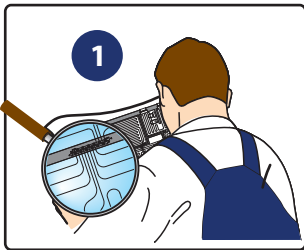



4.3 INSTALLATION OF THE PIPE - POSA DEL TUBO

15

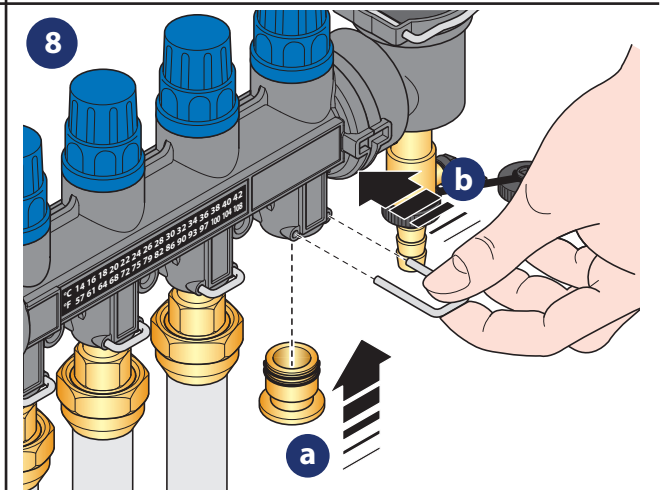
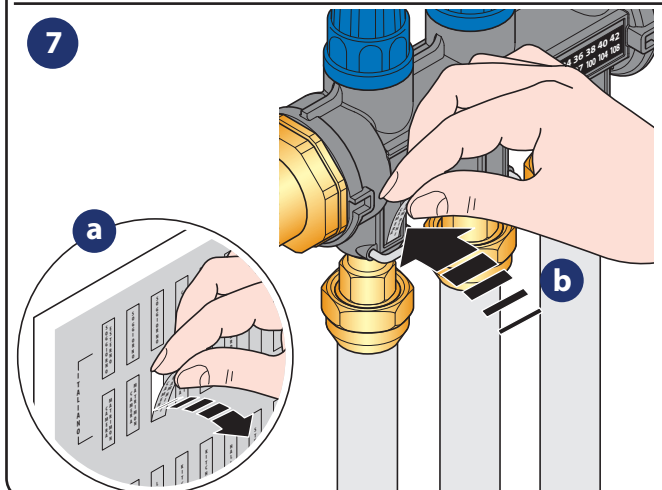
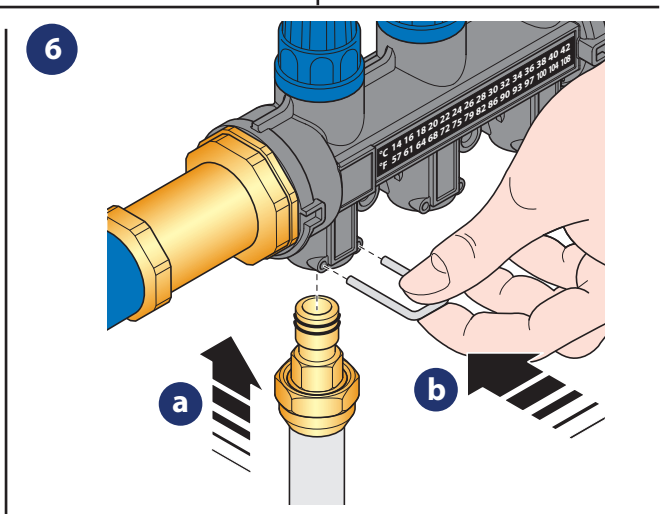
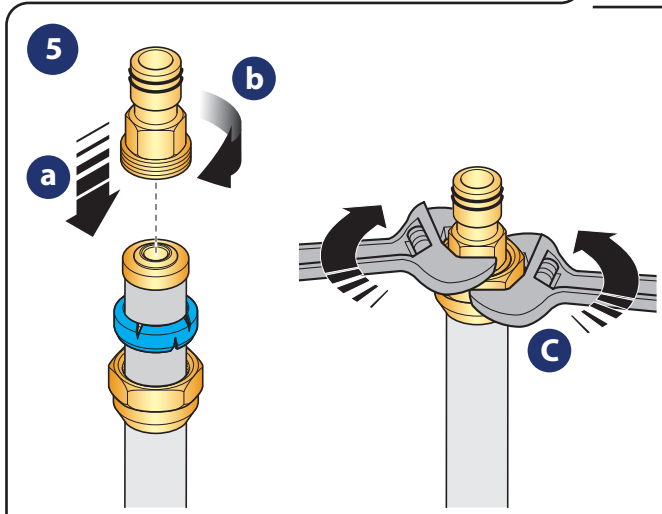
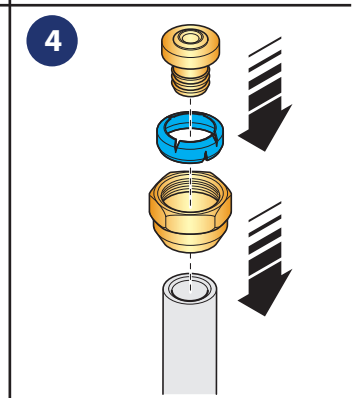
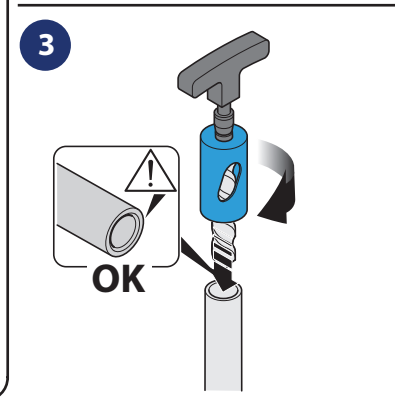
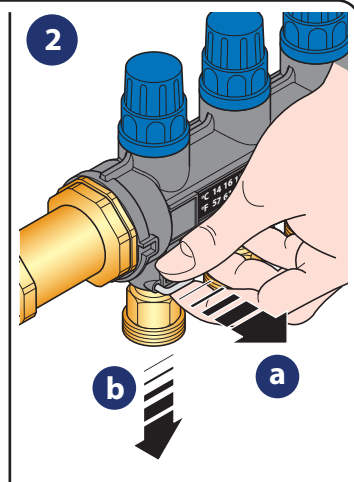
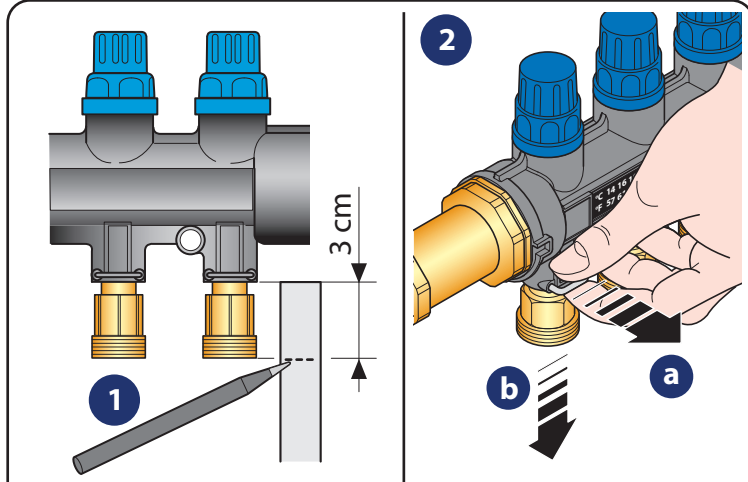
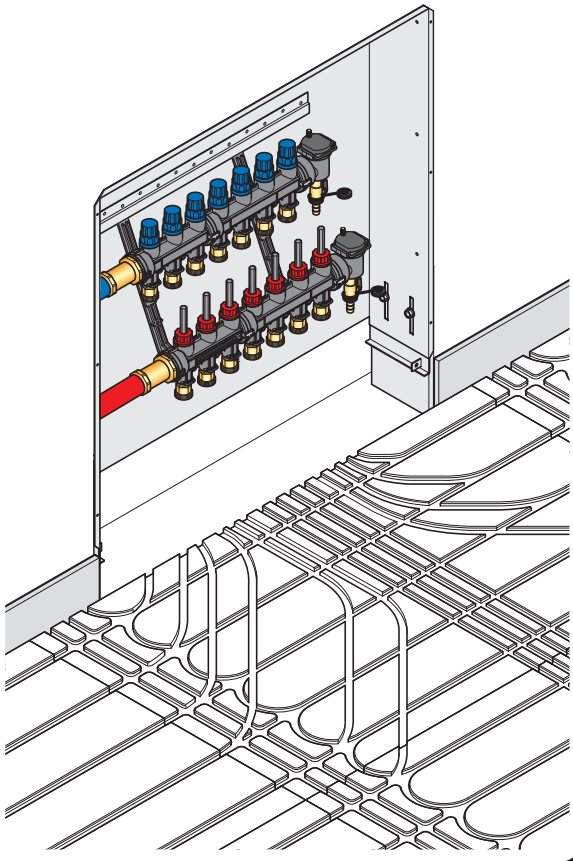

16

Milling machine intervention area
Zona di intervento fresatrice

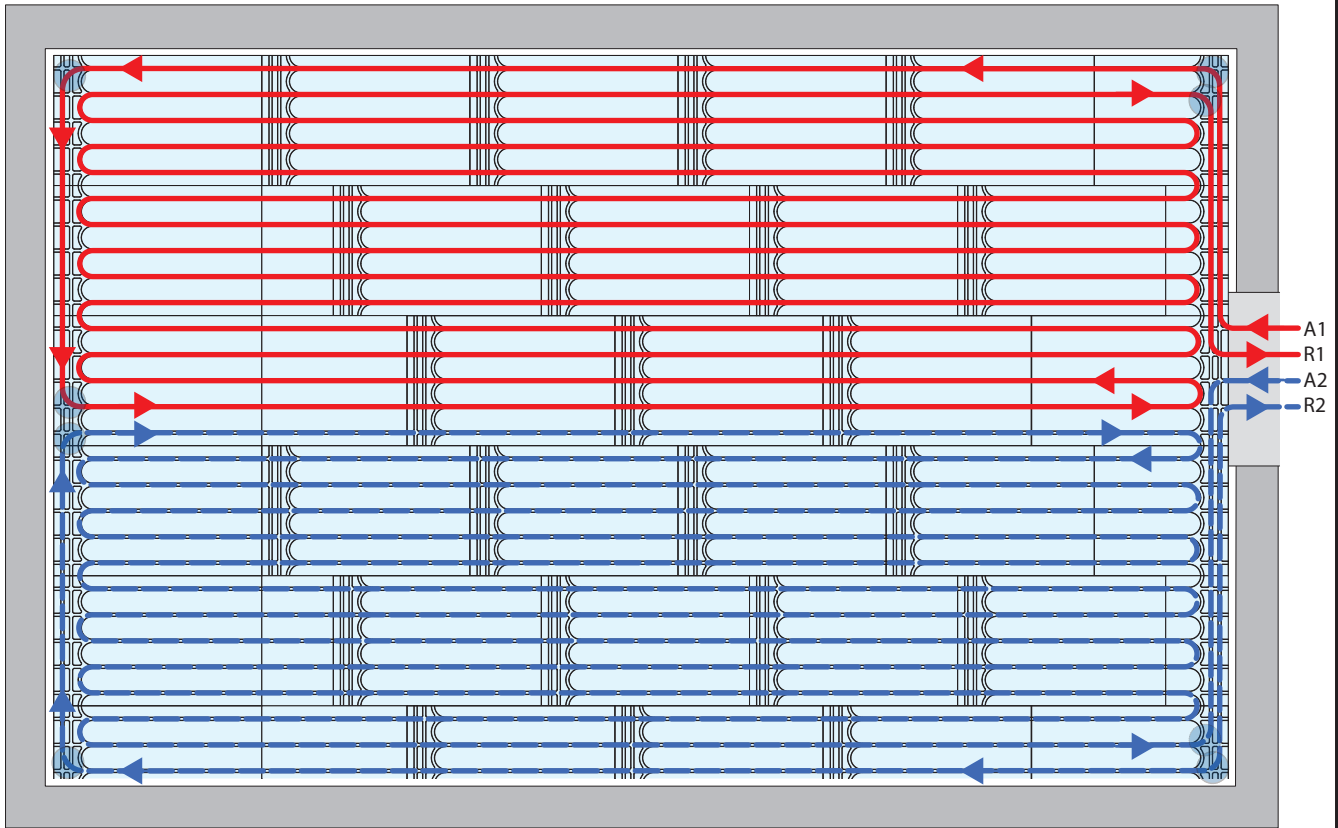

17

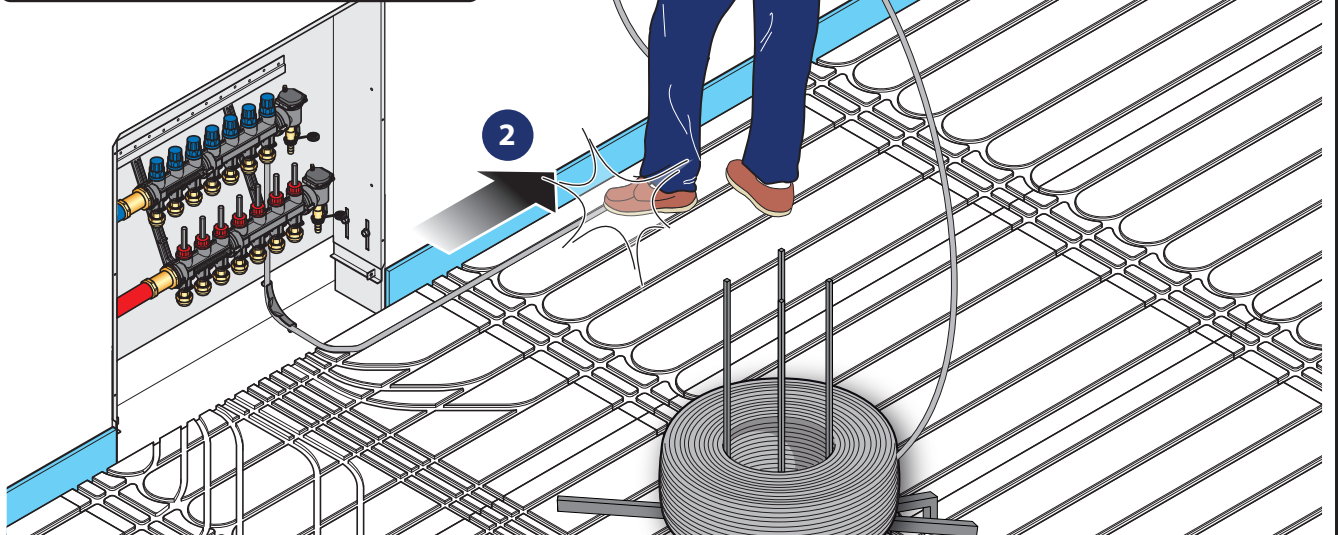
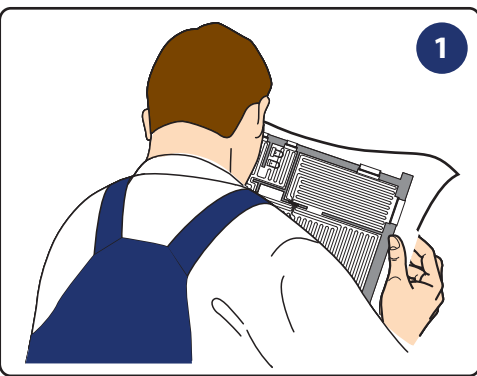



18

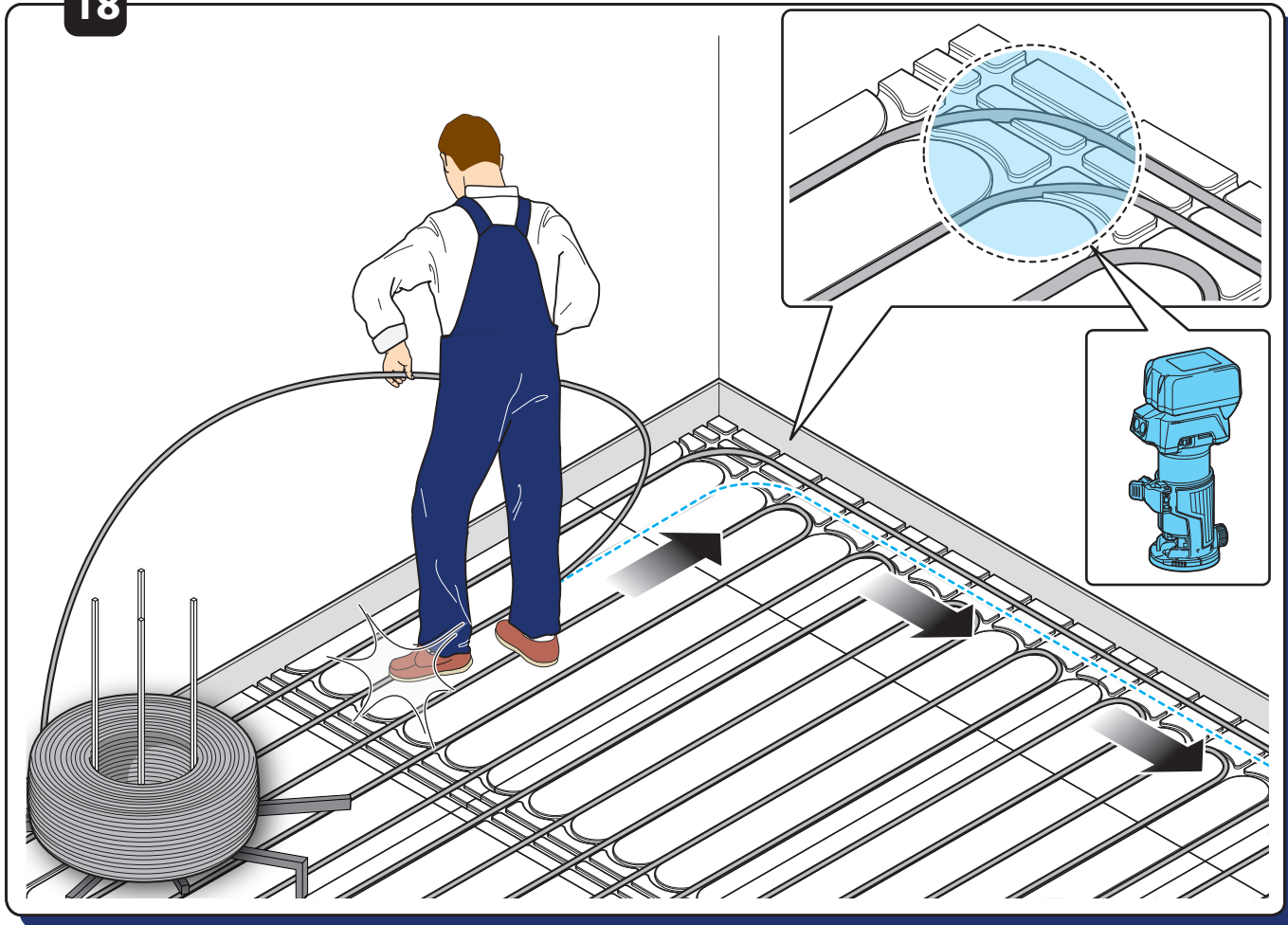

19

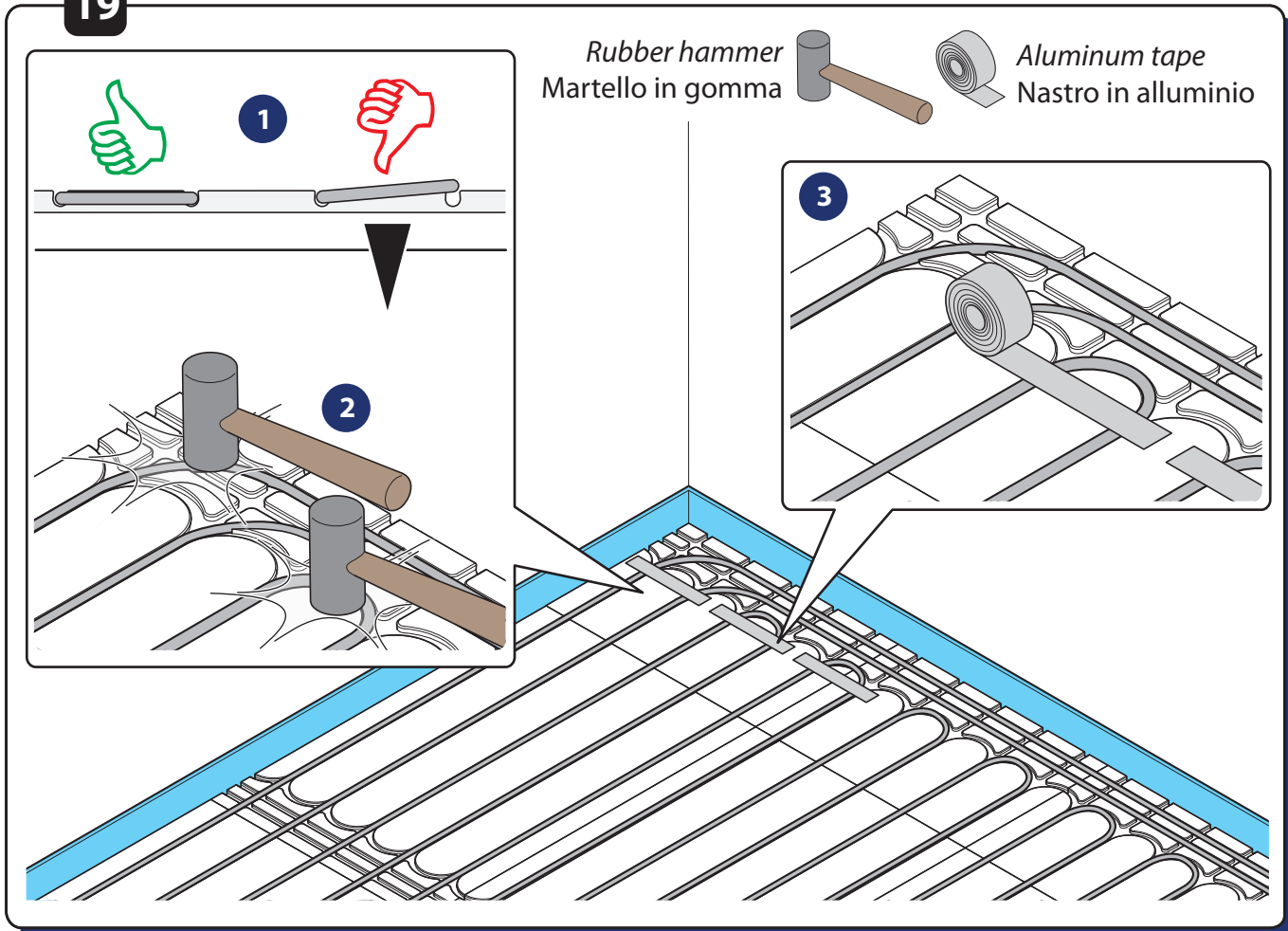

20

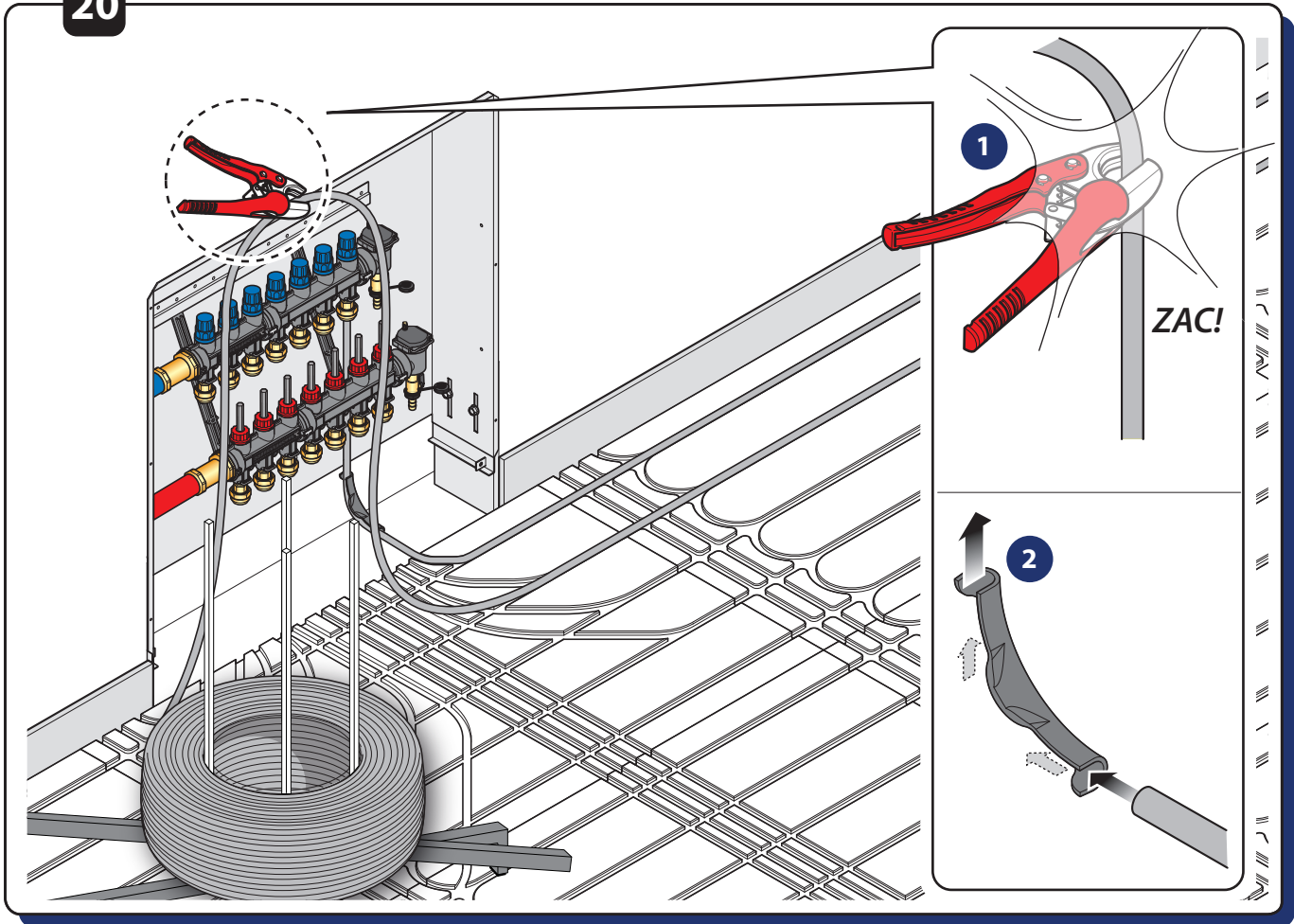

21

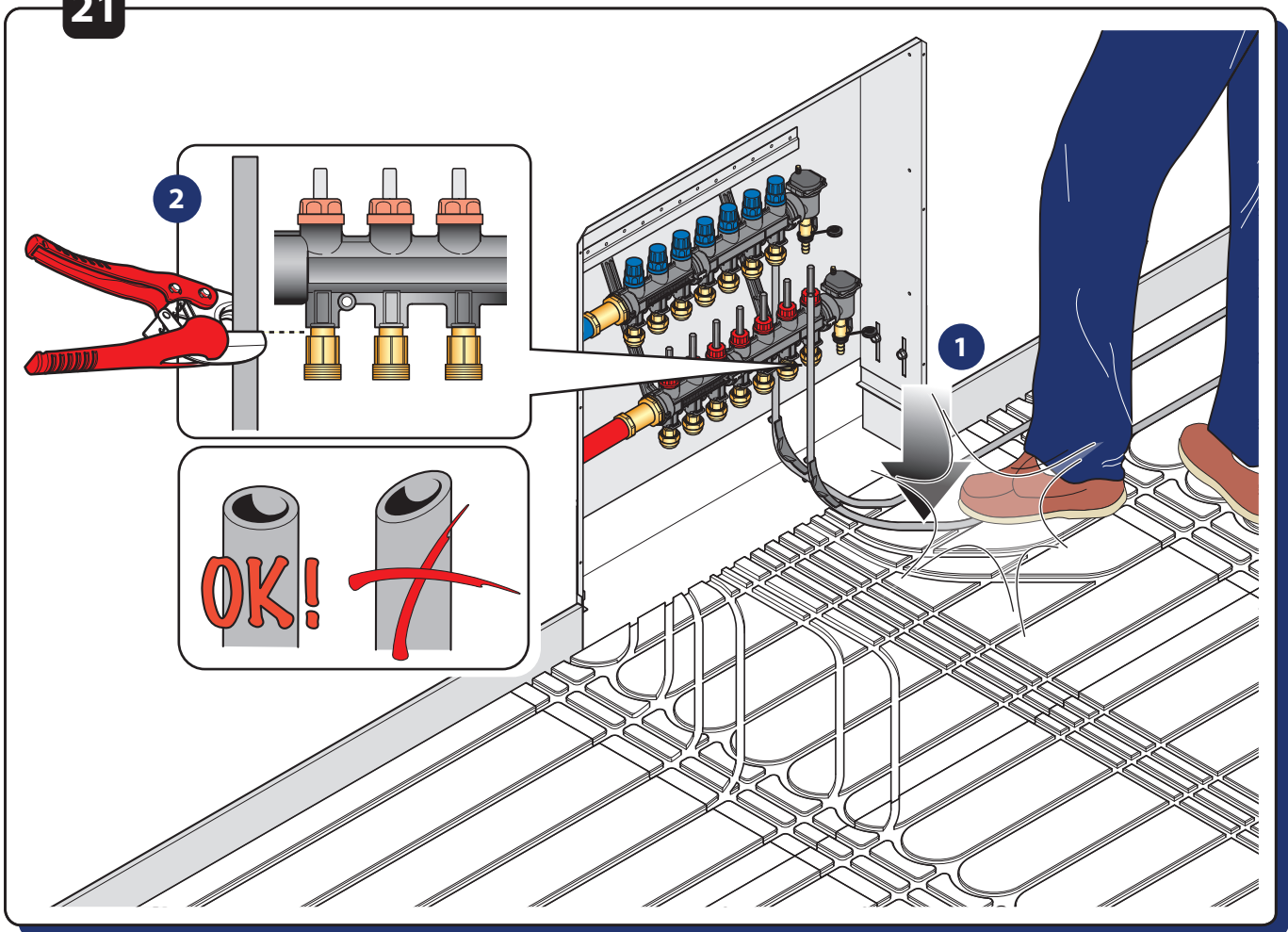



22

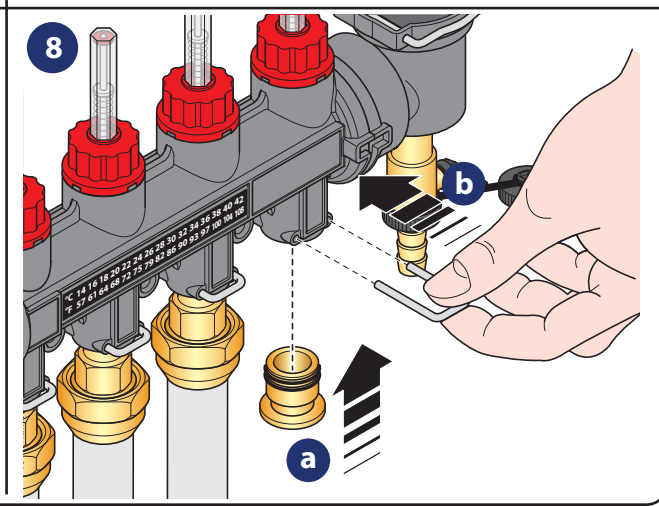
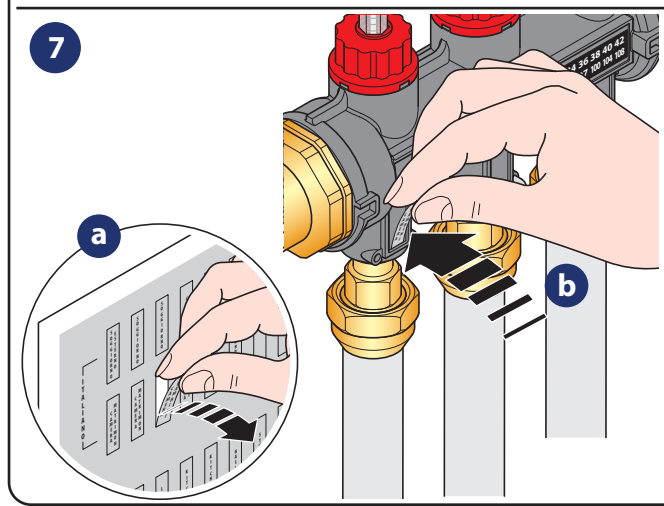
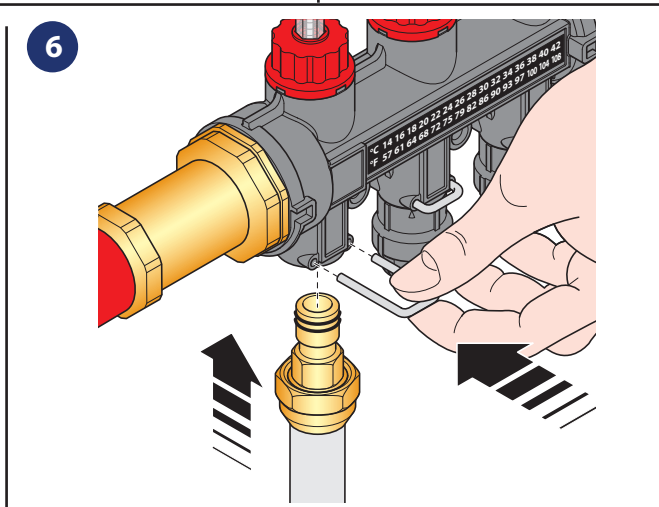
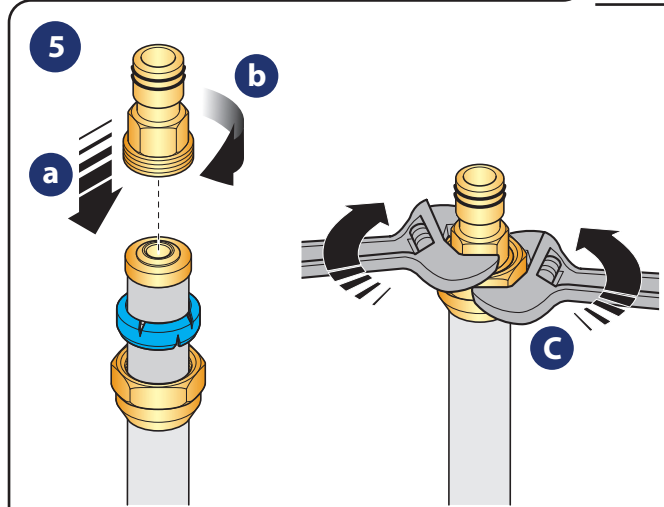
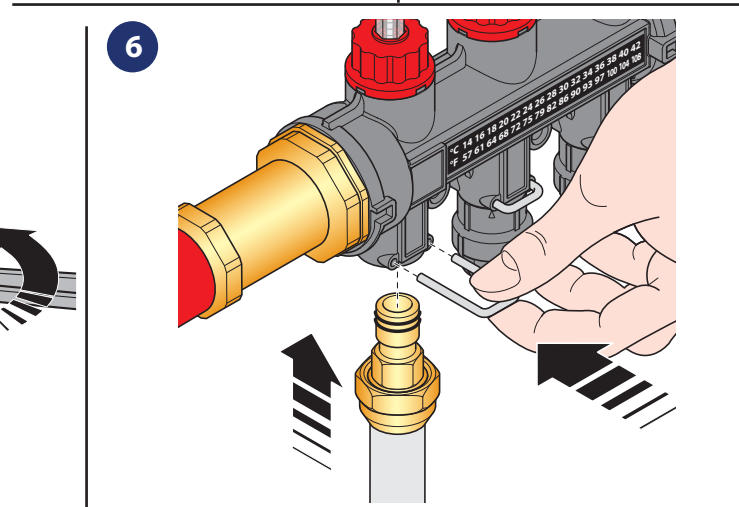
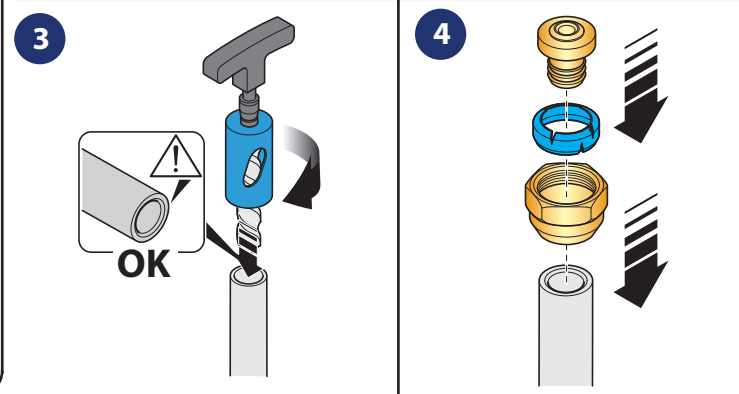
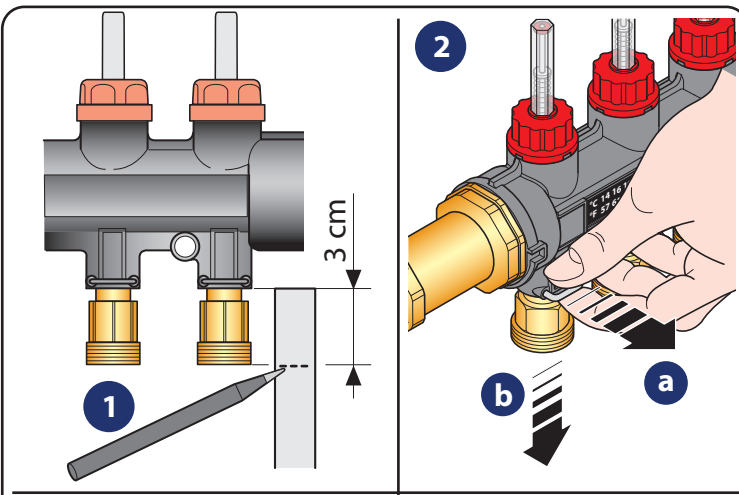
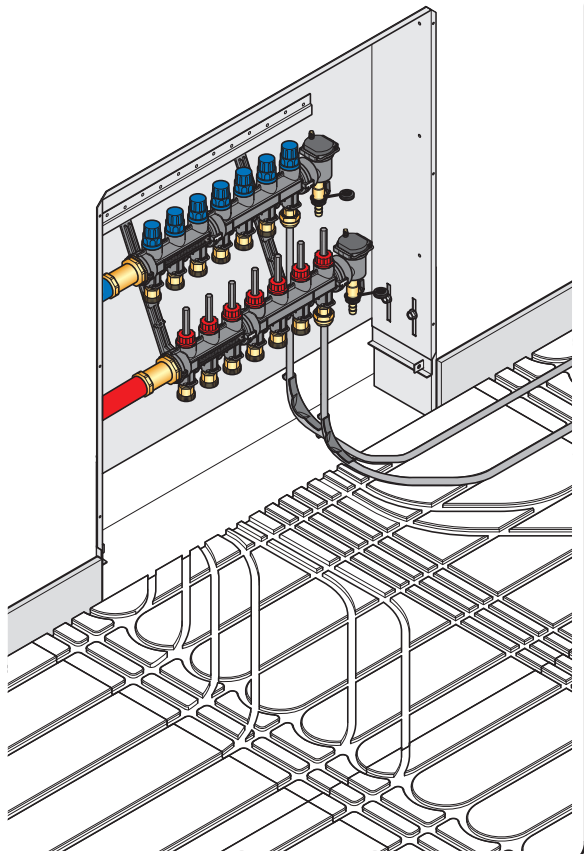

4.4 INSTALLATION OF THE WEIGHT DISTRIBUTION LAYER - POSA DEL RIPARTITORE DI CARICO

Before starting the installation of the load distributors, check for the presence of any critical areas (for example, accidental crushing of the panel in the edges) or obstacles in the substrate where it was not possible to lay the e-dry panel and be careful to apply in those areas polyurethane foam at the same time as the load divider with adequate weight.

Prima di iniziare la posa dei ripartitori di carico verificare la presenza di eventuali zone critiche (esempio schiacciamenti accidentali del pannello nei bordi) o ostacoli del sottofondo dove non è stato possibile posare il pannello e-dry e avere l'accortezza di applicare in quelle zone schiuma poliuretanicamente contestualmente al ripartitore di carico con peso adeguato.

23

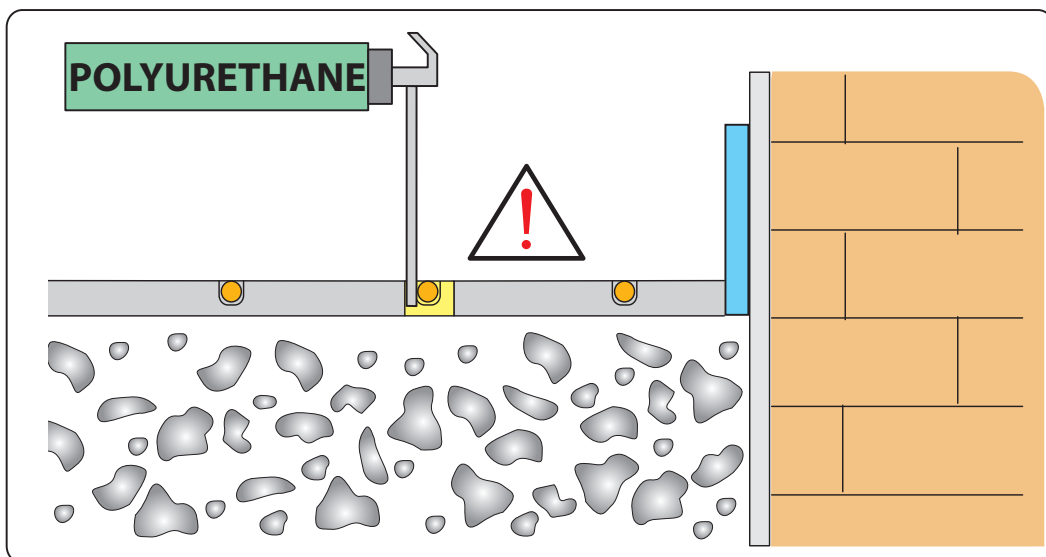
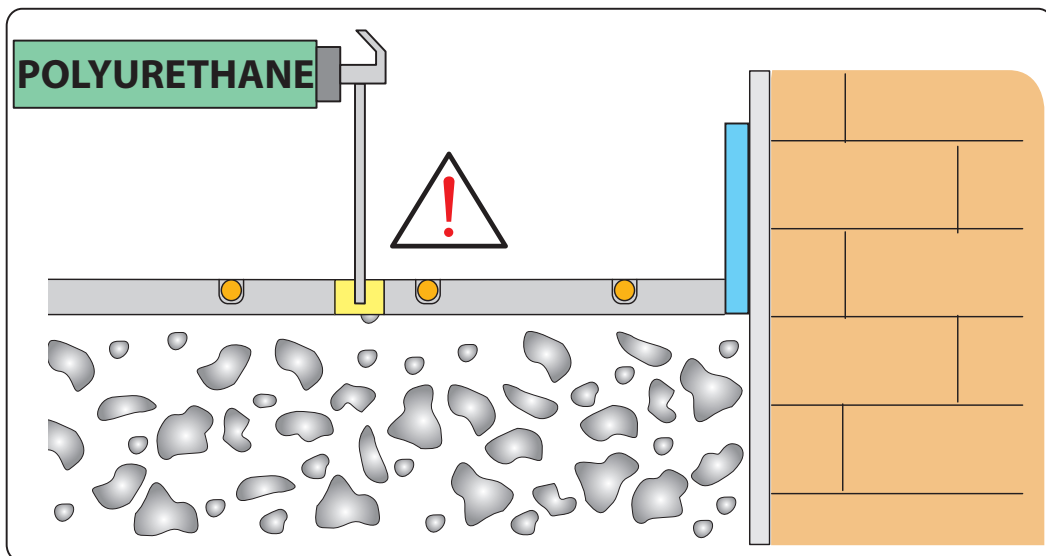
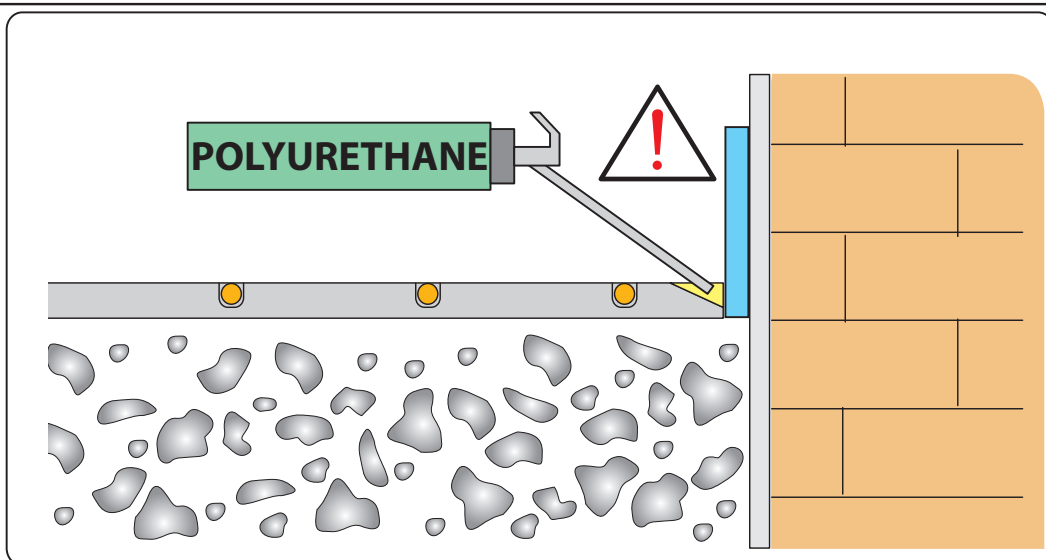



24

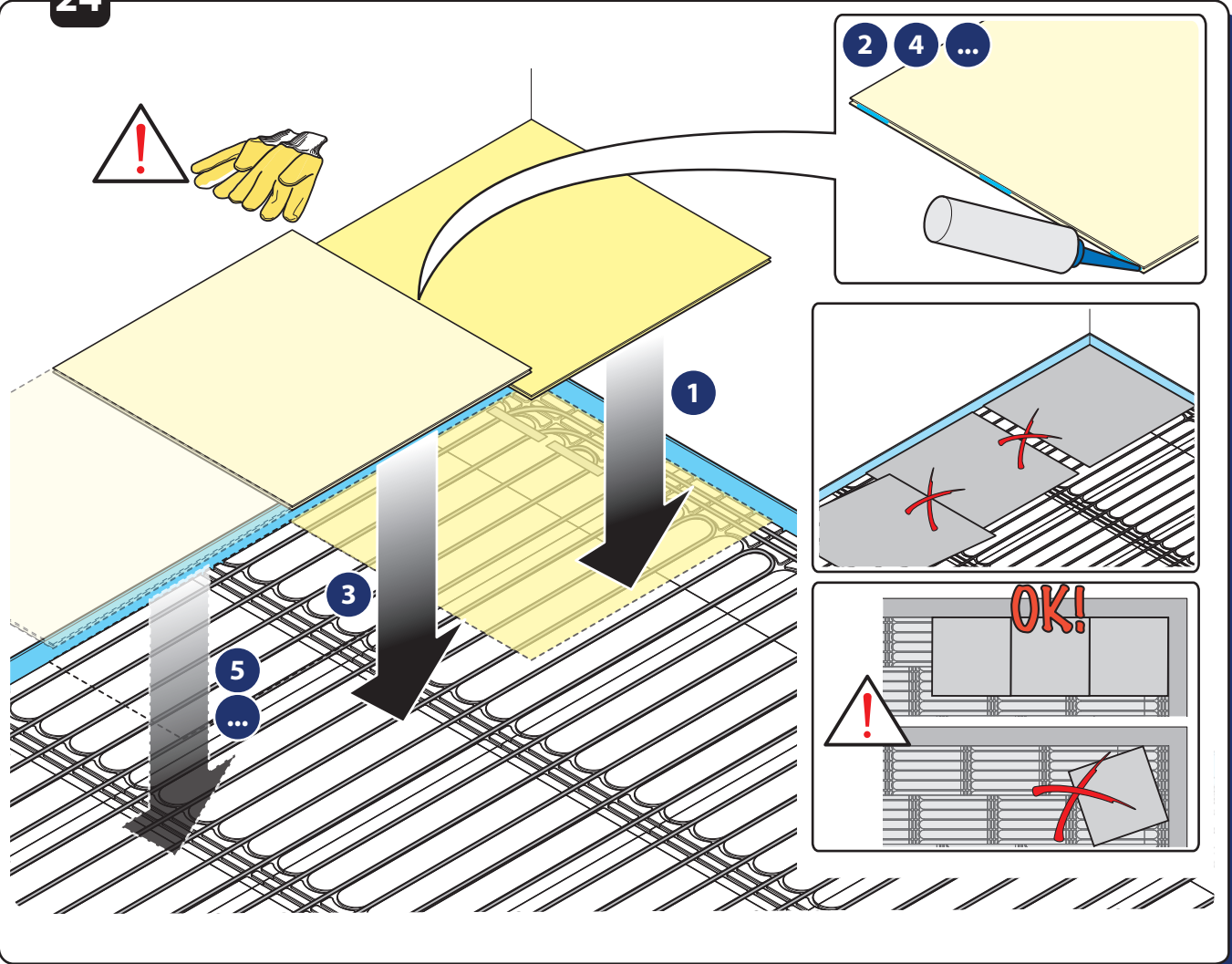

25

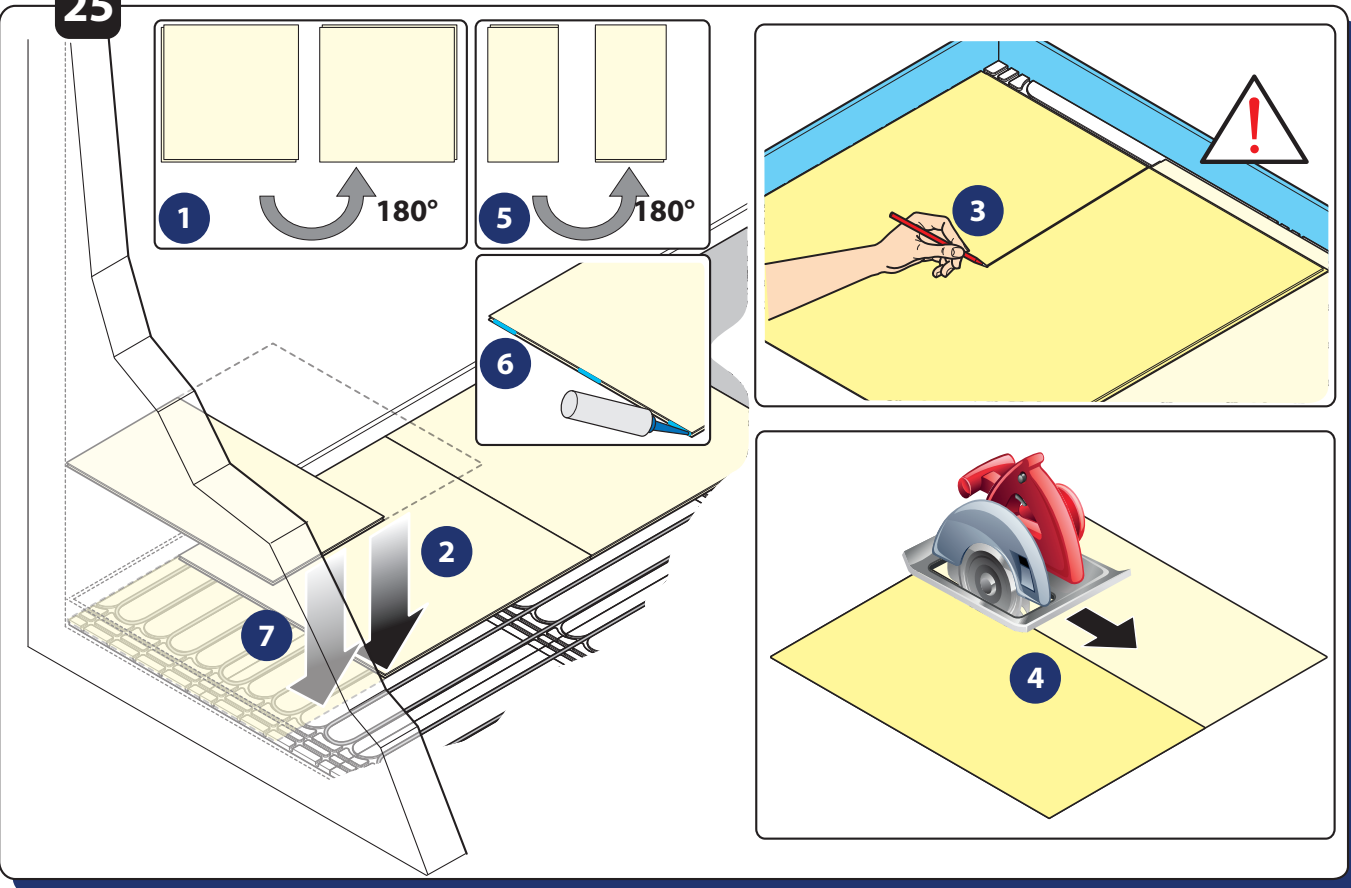



26 A

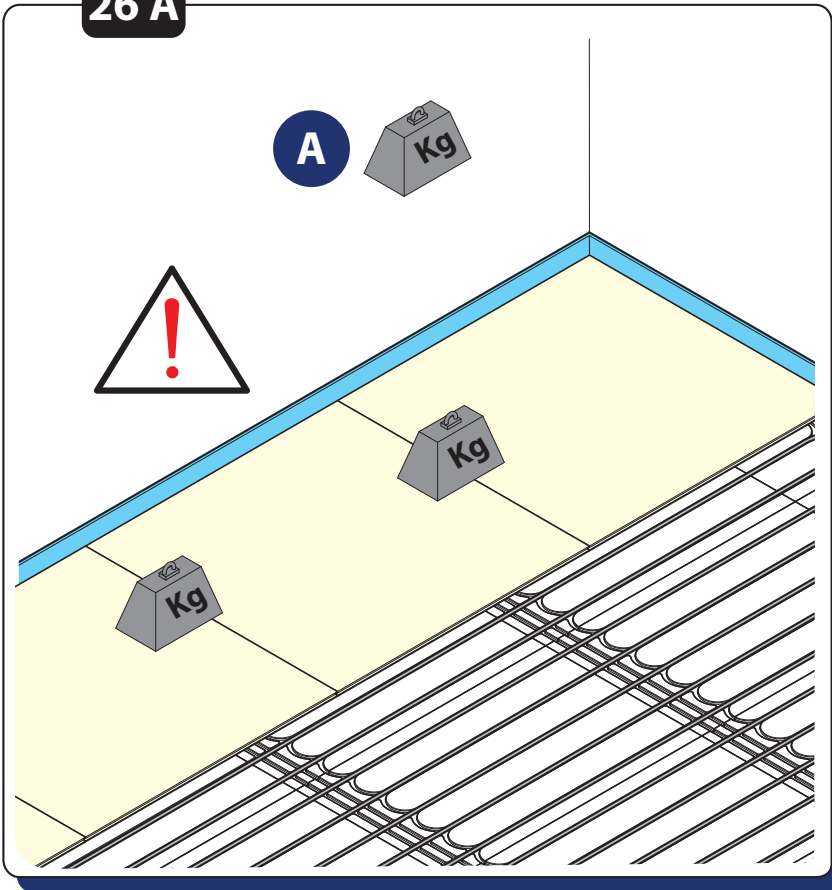

26 B

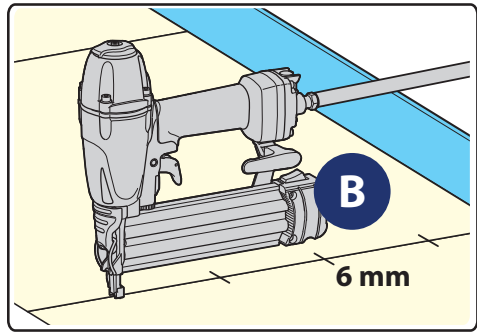

As an alternative to the use of weights, it is possible to fix the load distributors using no. 4 x 6mm metal staples on each side of the joint.

In alternativa all'utilizzo dei pesi è possibile fissare i ripartitori di carico tramite nr. 4 graffette metalliche da 6 mm su ogni lato di giunzione.

27 A

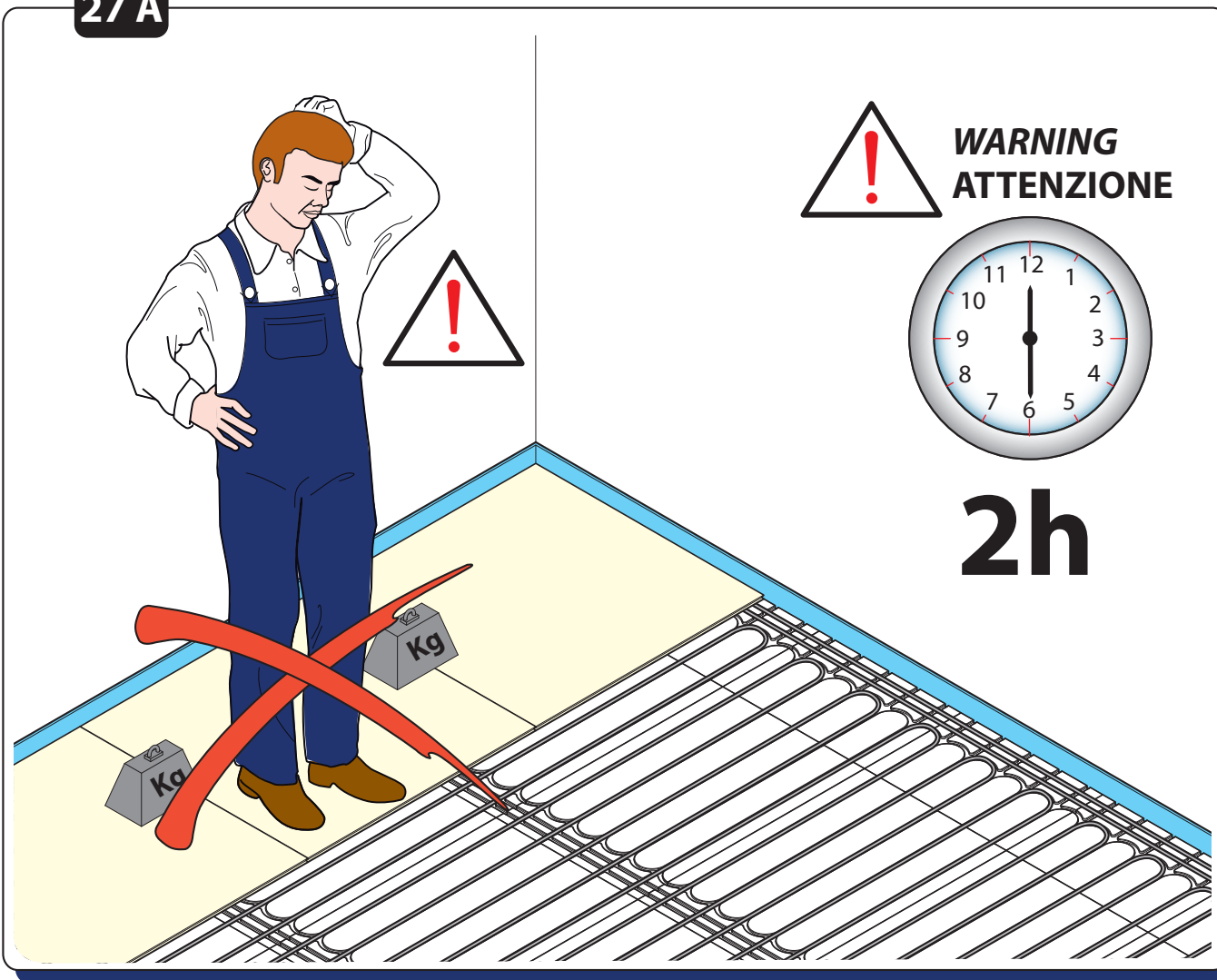



28

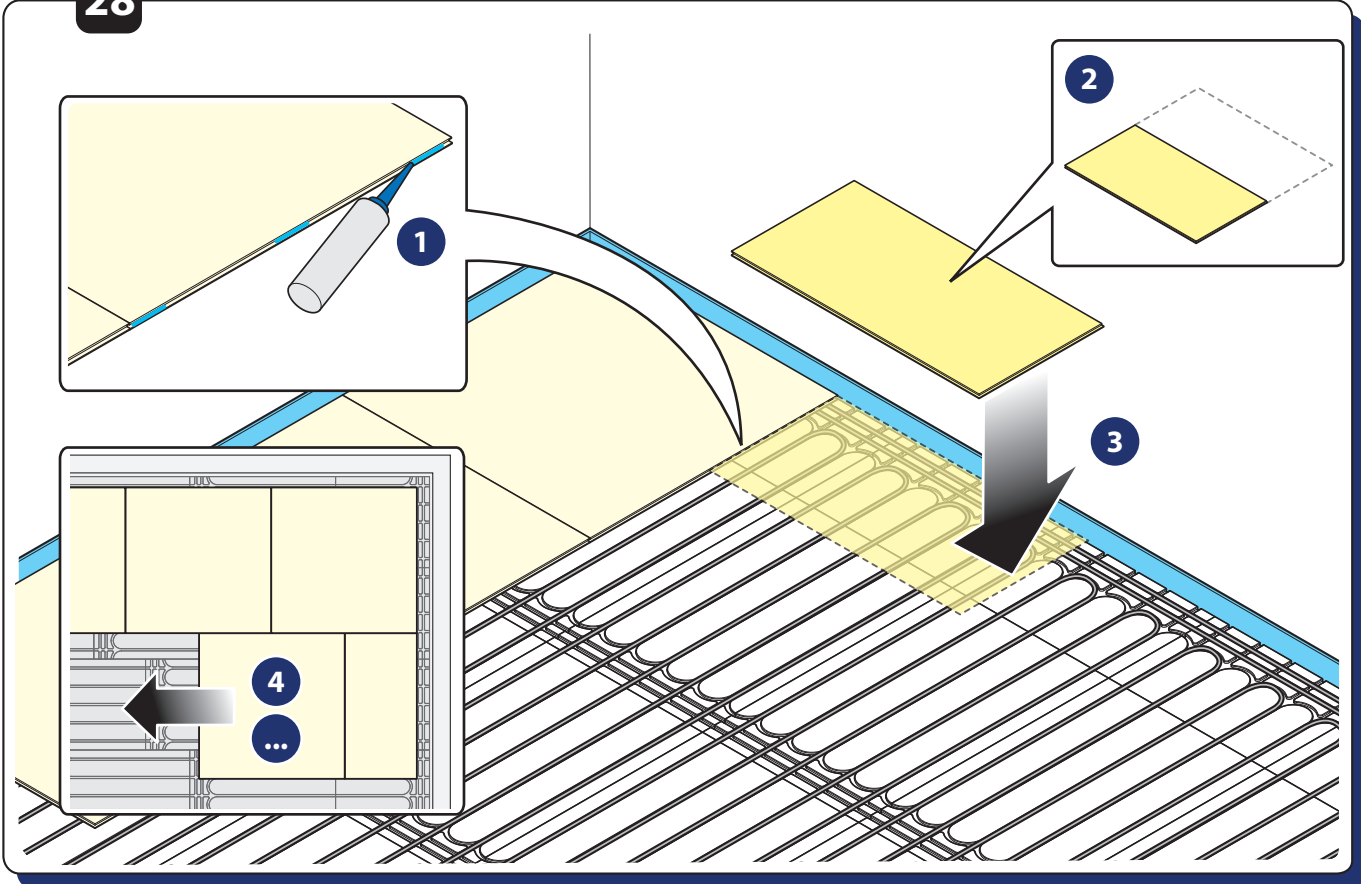

29

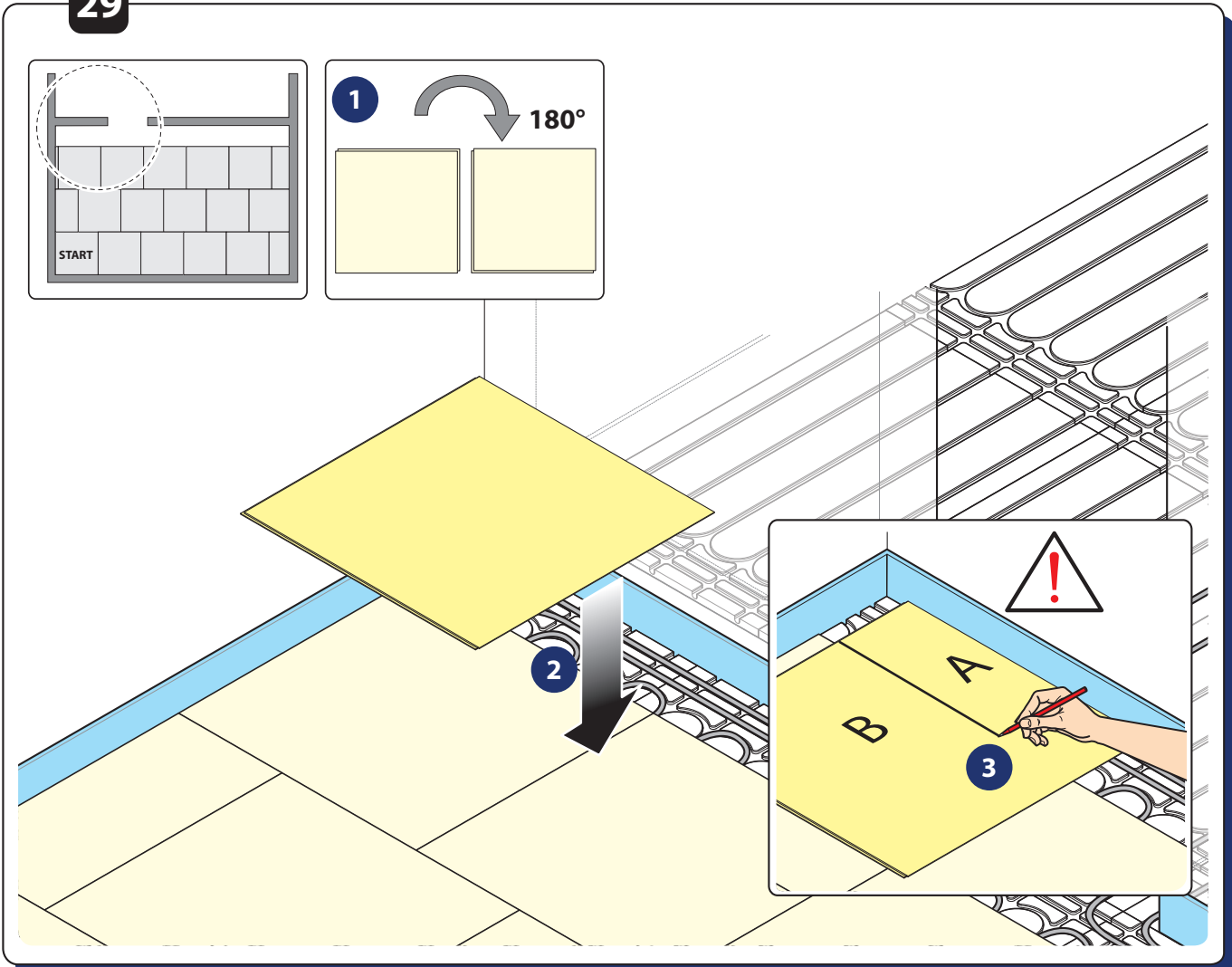



30

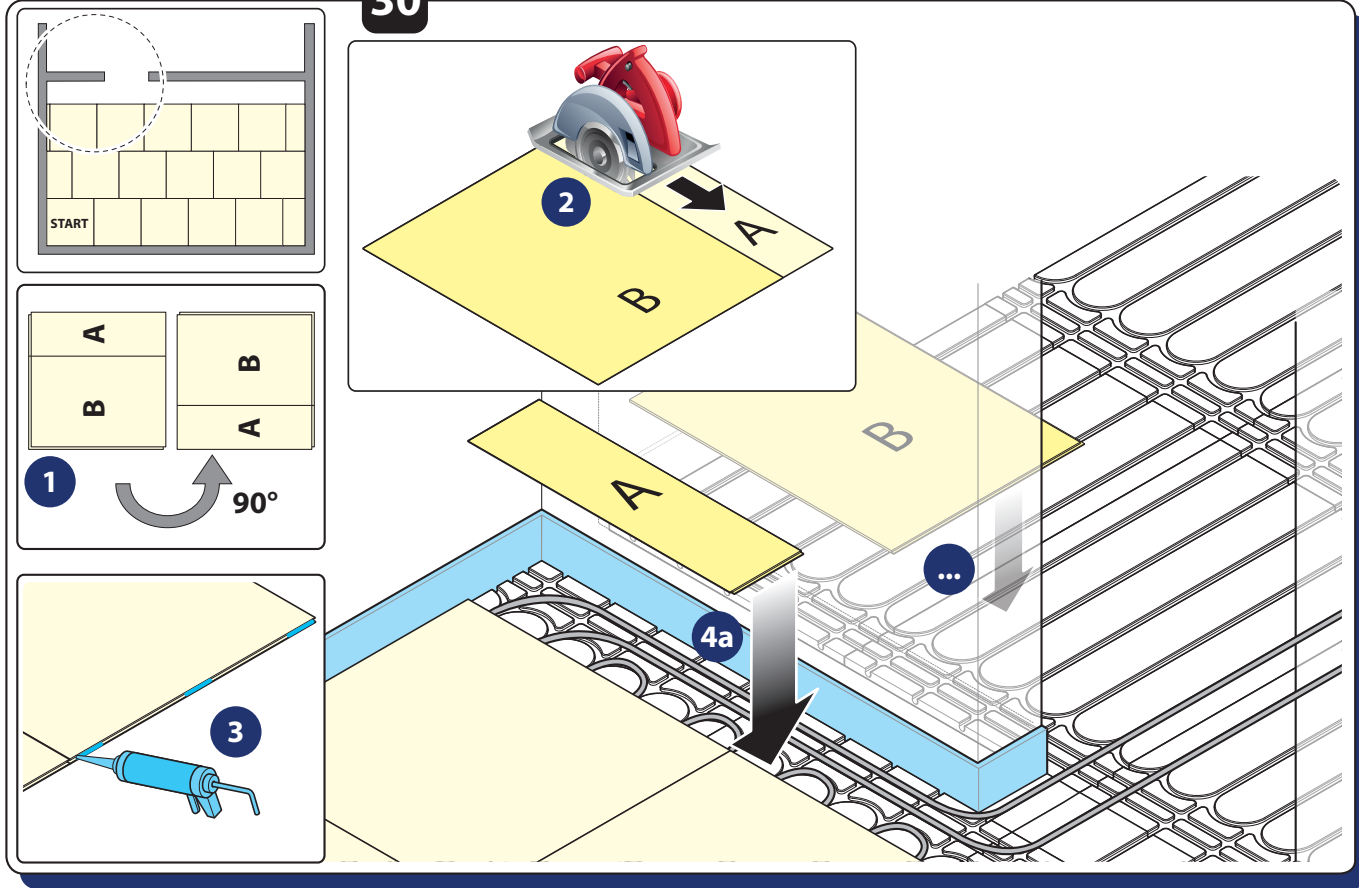

31

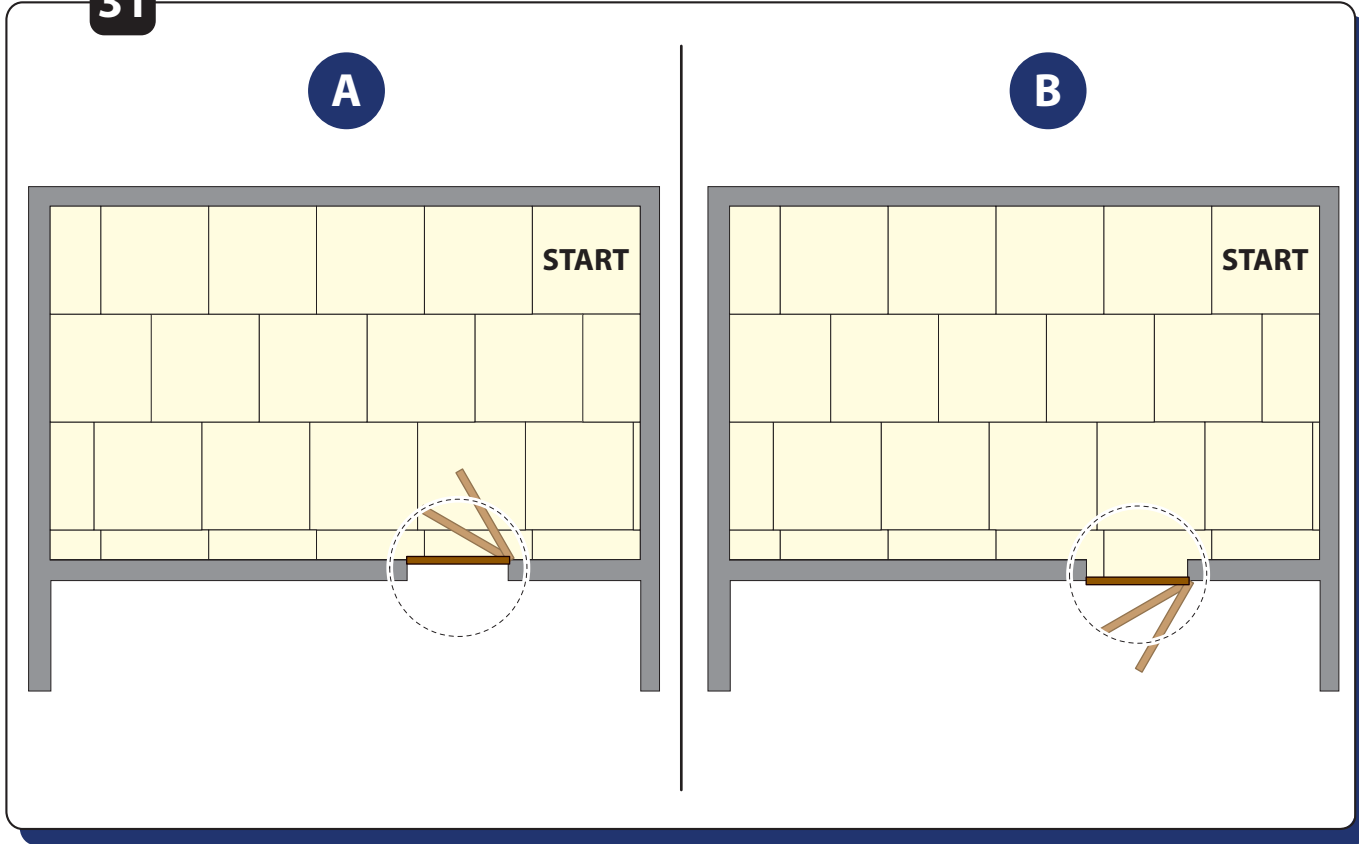



32 A

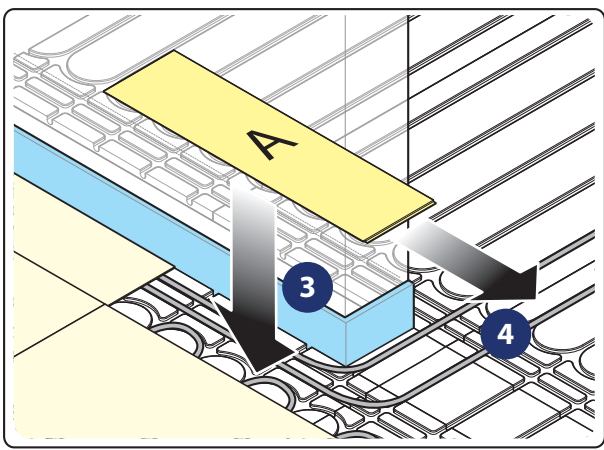
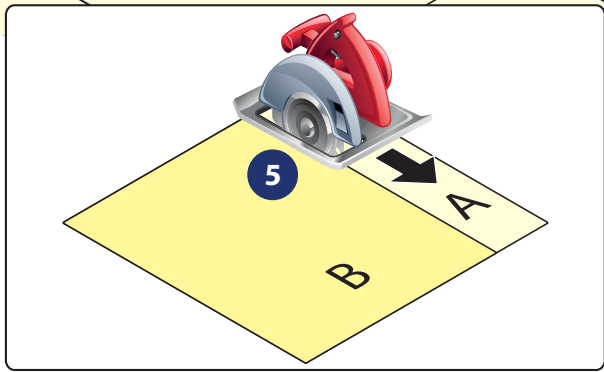
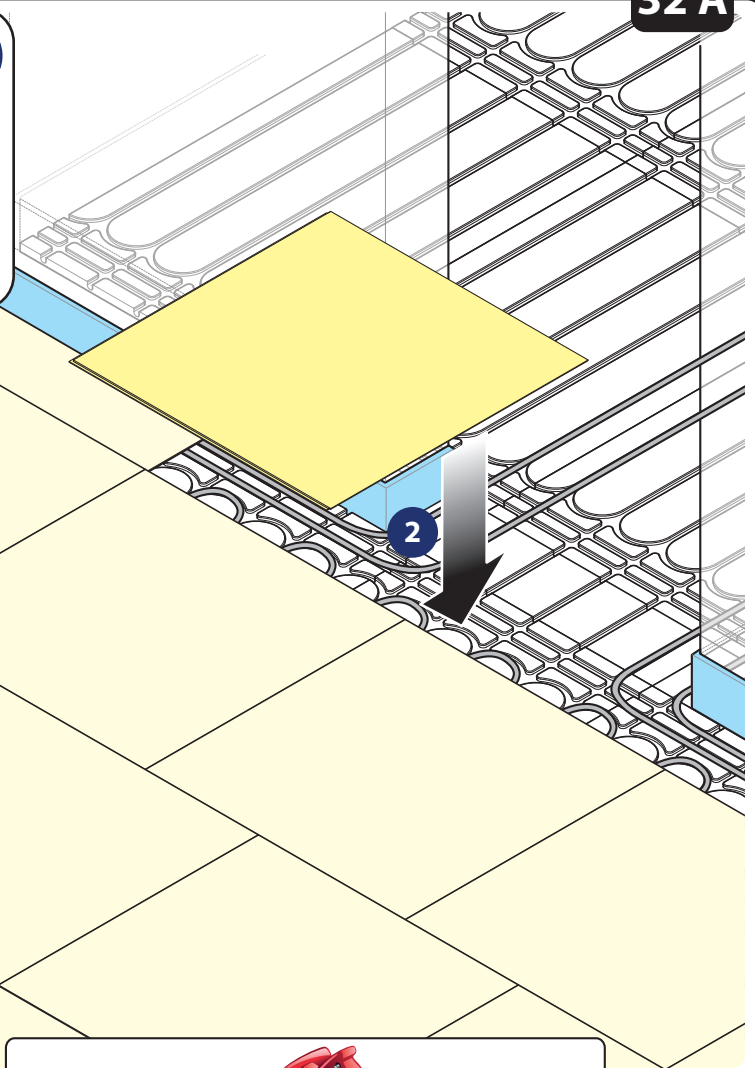
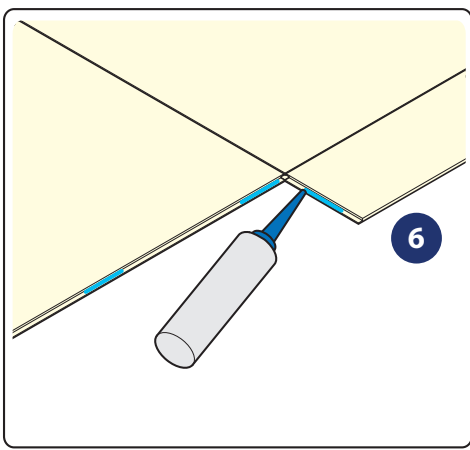
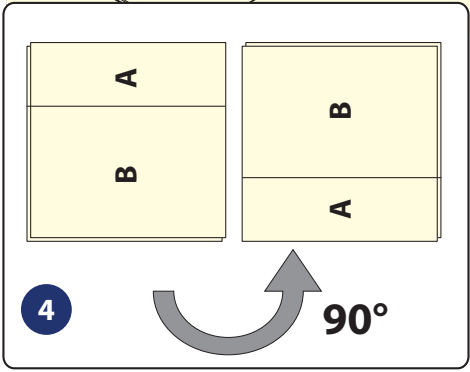
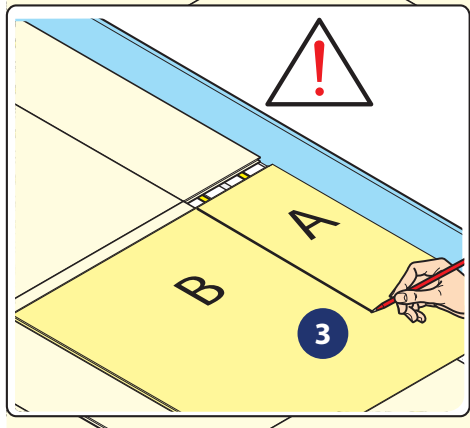
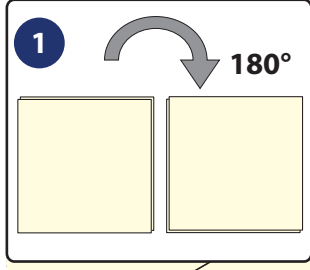
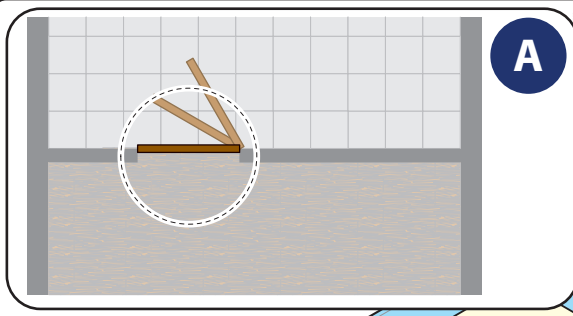

CONTINUE WITH STEP "35"
CONTINUARE POI CON LA SEQUENZA "35"

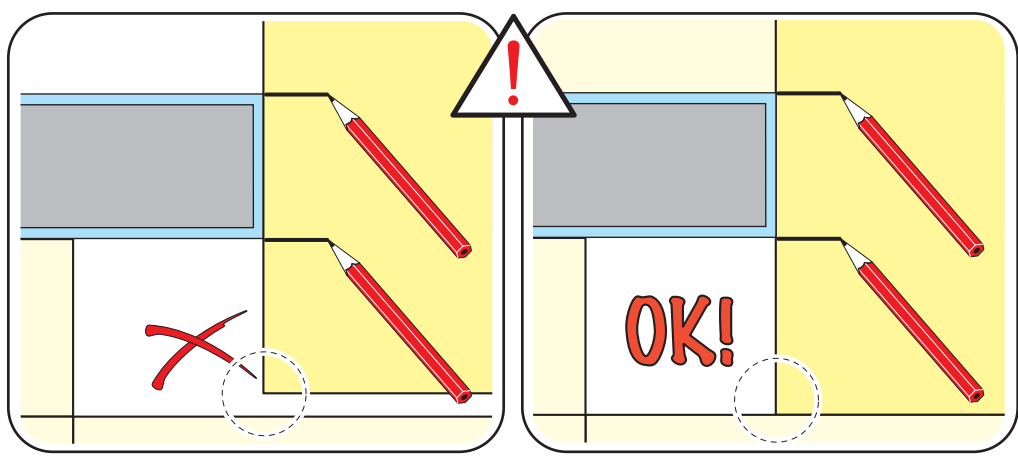
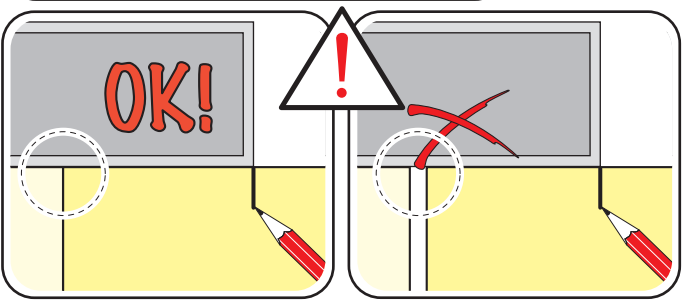
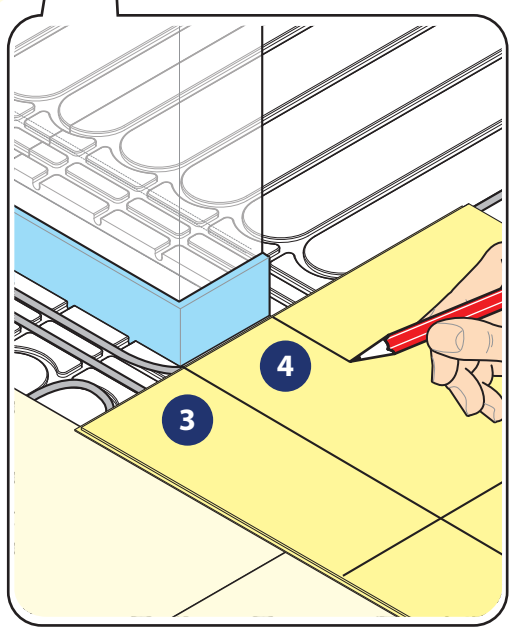
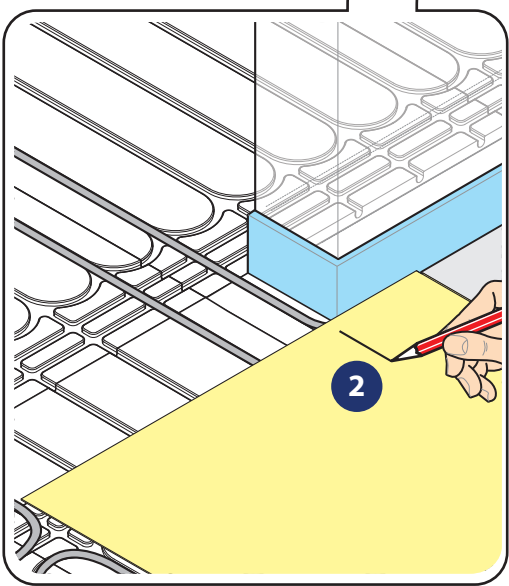
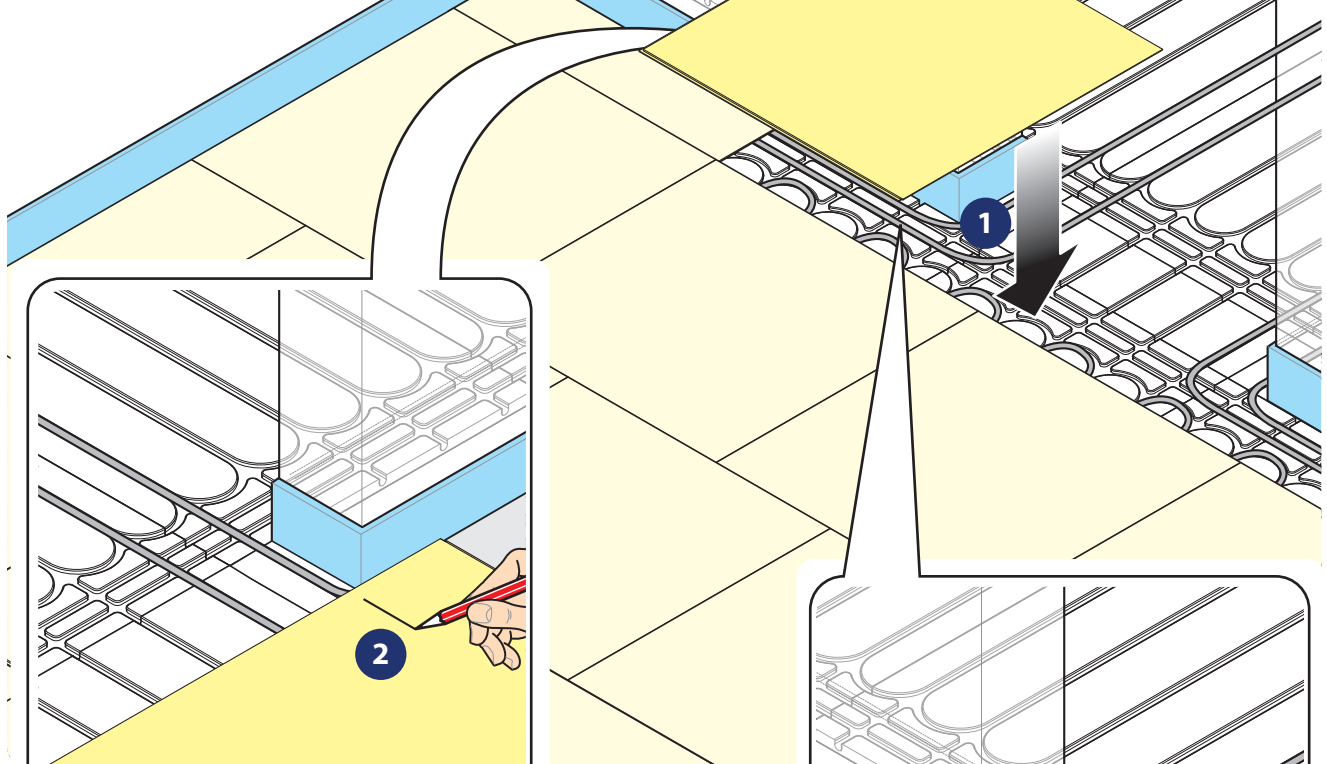
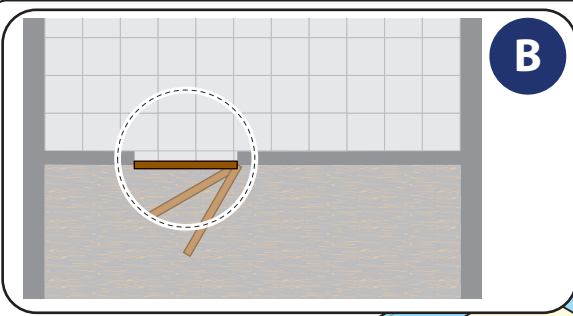



33 B

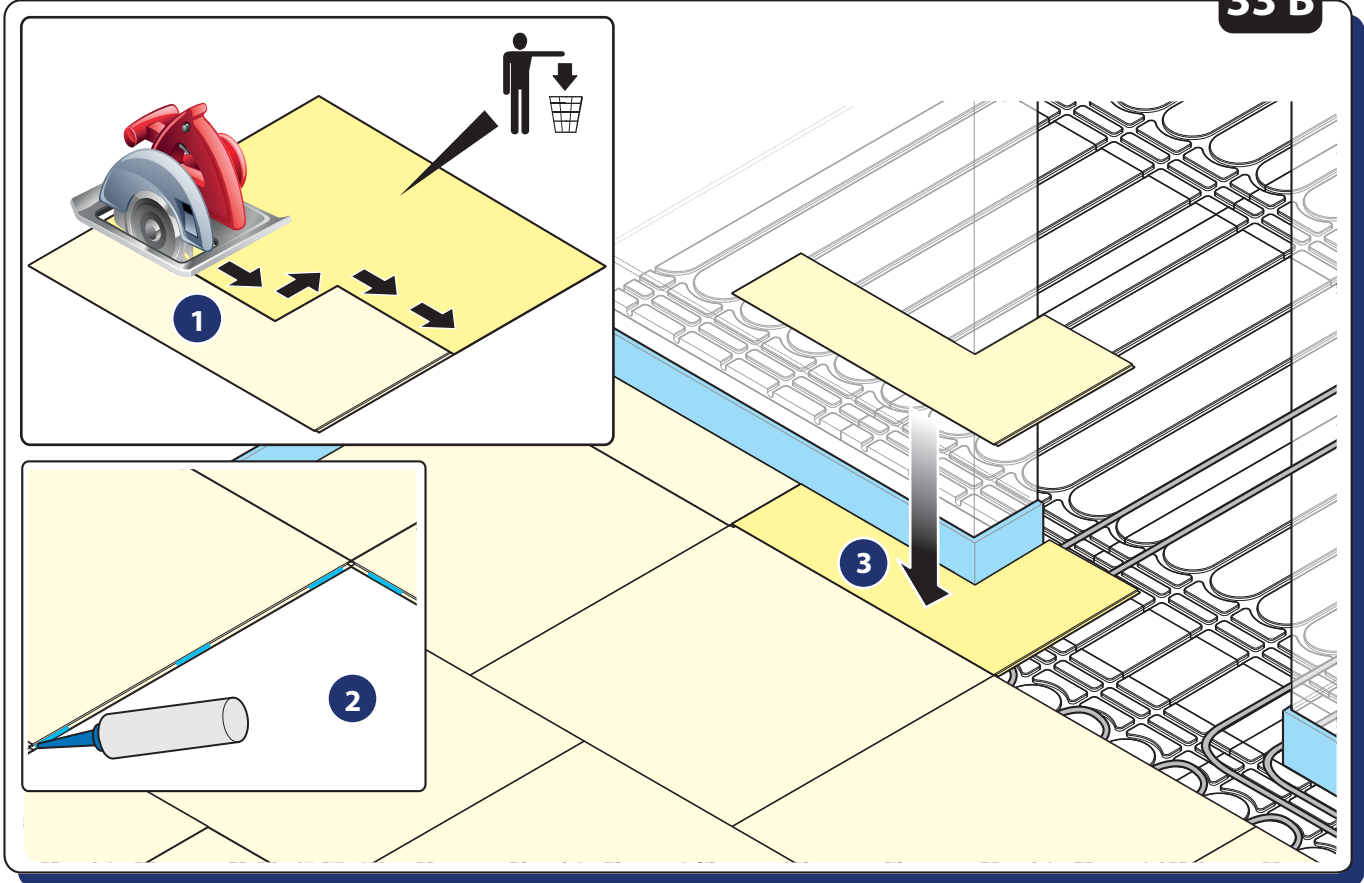

34 B

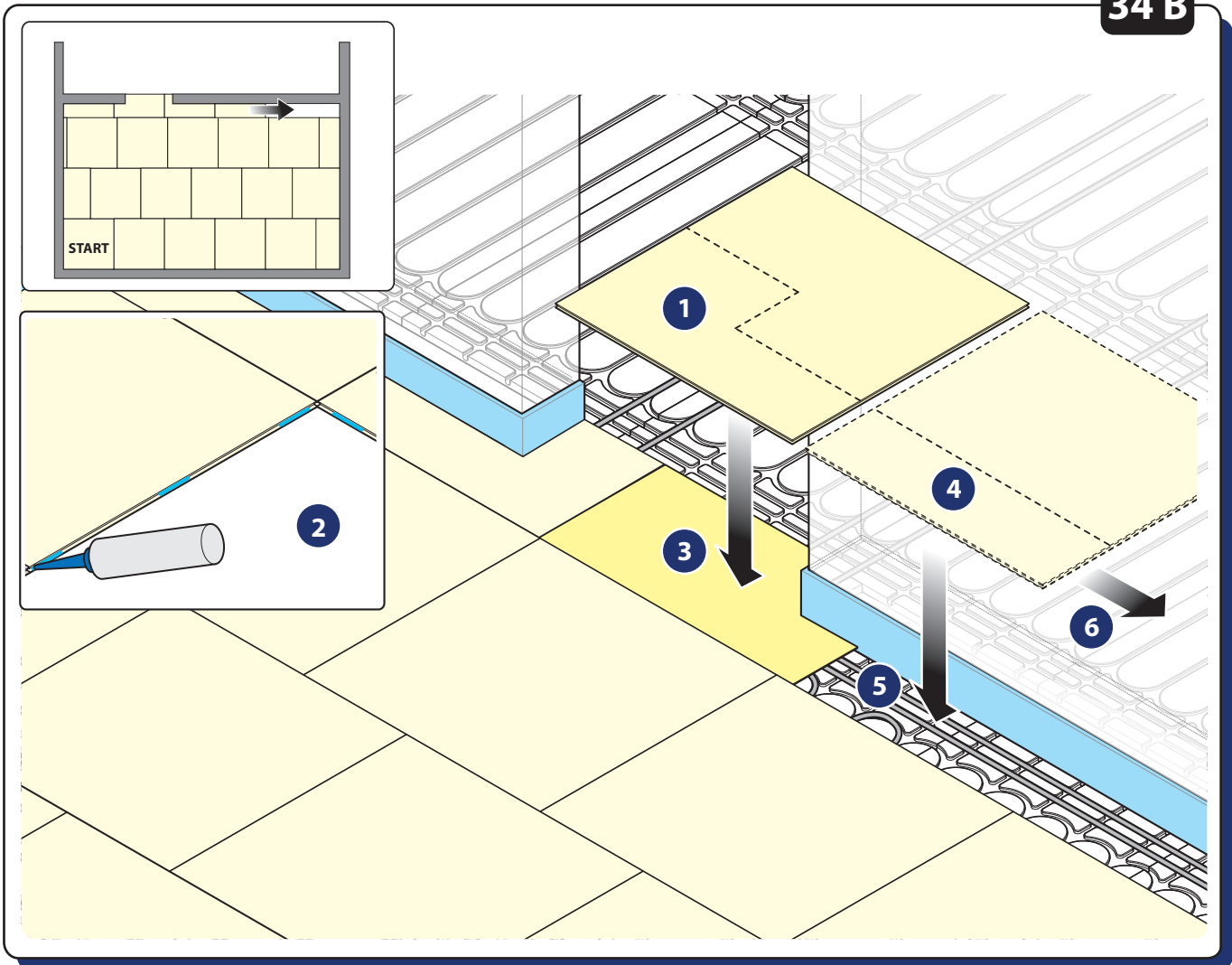



35

A



WARNING
ATTENZIONE



2h

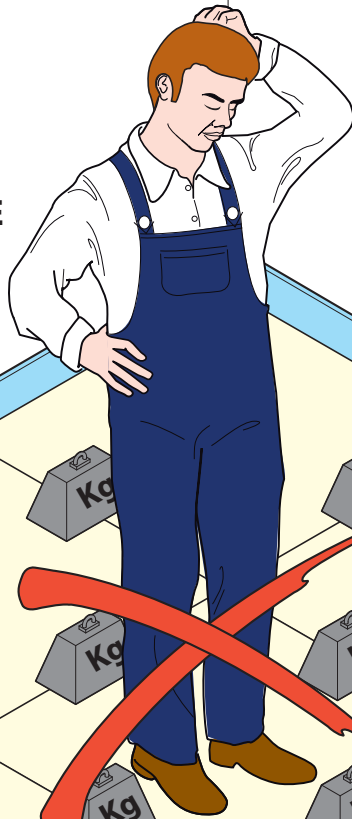

B

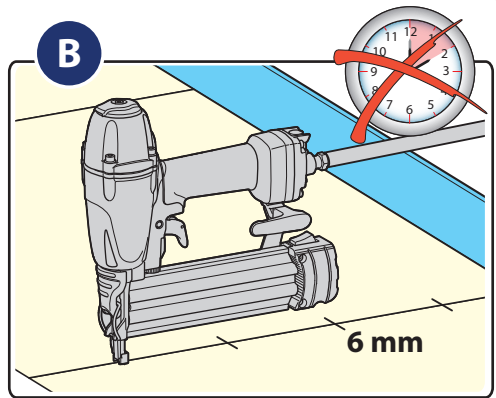

6 mm

36

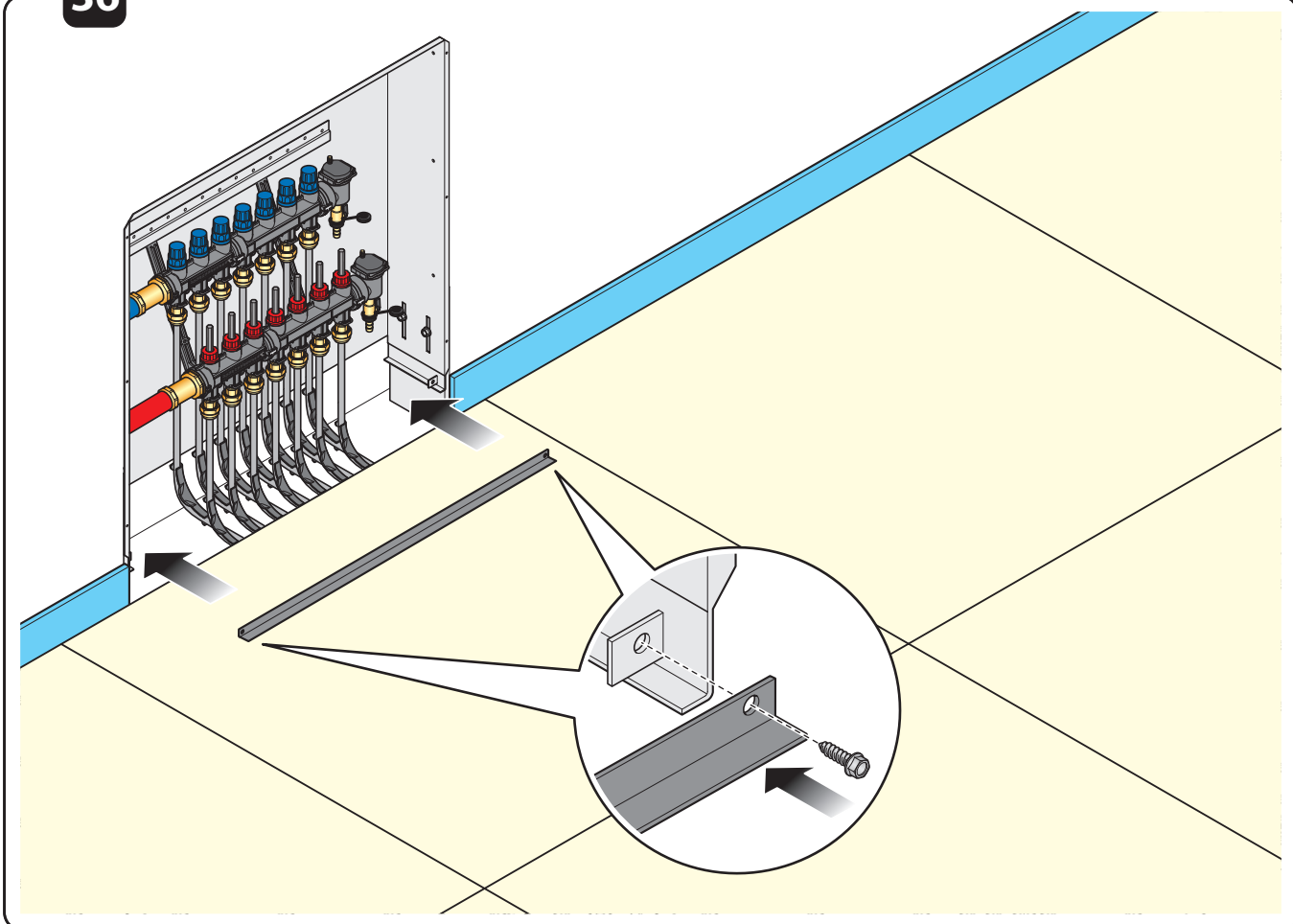

4.5 SYSTEM FILLING - RIEMPIMENTO IMPIANTO

37

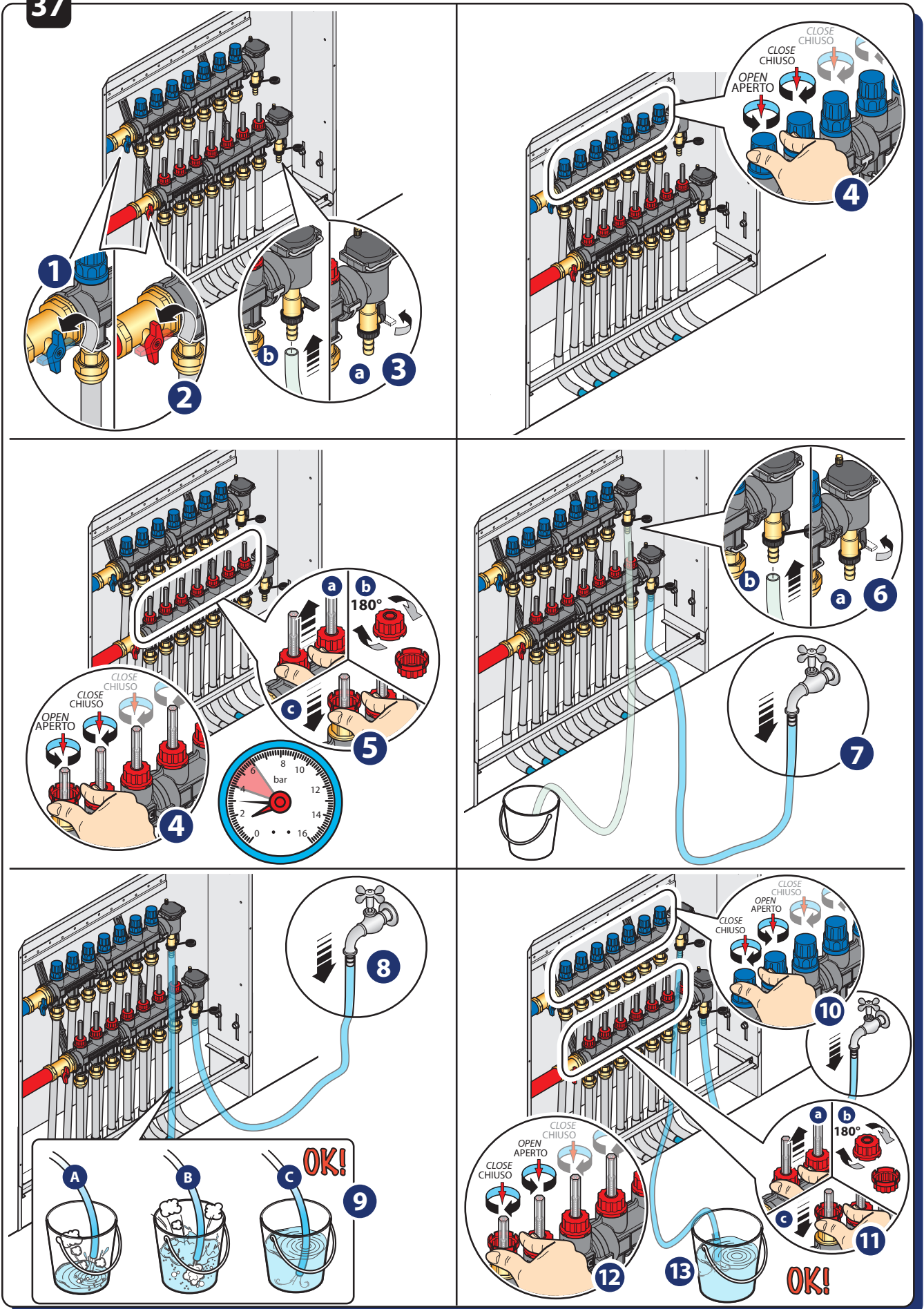

The system shall be kept with pressure until the work is finished (flooring excluded)

La tenuta in pressione dell'impianto dovrà avvenire fino al completamento dei lavori (rivestimenti esclusi)



38

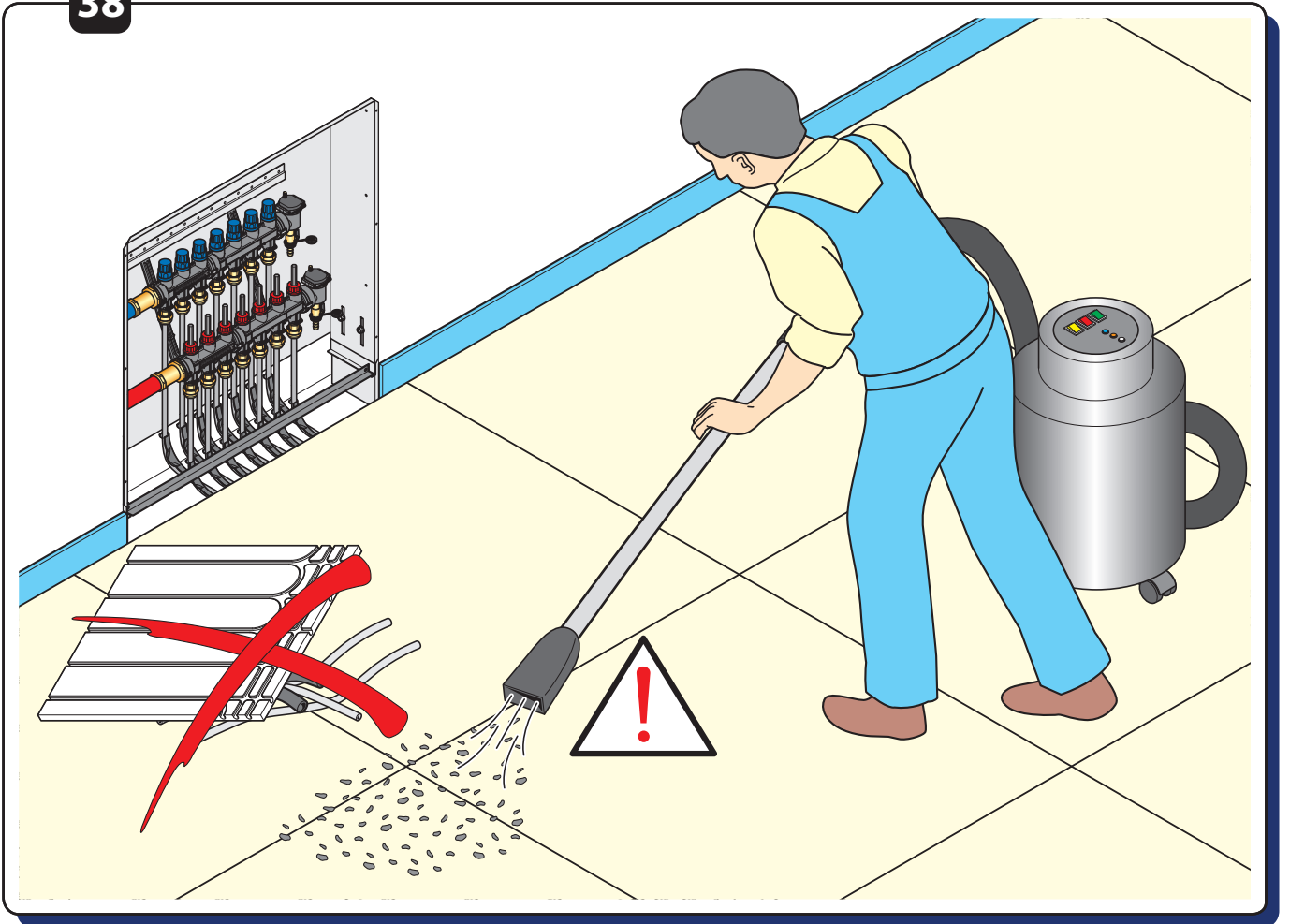



INSTRUCTIONS FOR ALLOWED DIMENSIONS /GROUTING

INDICAZIONI PER DIMENSIONI CONSENTITE E FUGHE

FORMATS ALLOWED

Both for the installation of square tiles $X=Y$ and for the installation of rectangular tiles $X>Y$, the size of the longest side must not exceed 40 cm.

FORMATI CONSENTITI

Sia per la posa di piastrelle di forma quadrata $X=Y$, che per la posa di piastrelle a forma rettangolare $X>Y$, la dimensione del lato maggiore non deve superare i 40 cm.

GROUT

It is forbidden to use it with flooring without grout. The space between the tiles (≥ 4 mm) depends on the kind of the flooring and it shall consider any upright movement of the covering itself, even if limited, in order to avoid friction and breaking of the tiles before grouting.

FUGHE

E' vietata la posa di rivestimenti privi di fughe. Lo spessore delle fughe (≥ 4 mm) dovrà essere commisurato al formato del rivestimento adottato e comunque dovrà tener conto di eventuali movimenti verticali, anche se limitati del rivestimento, tutto ciò al fine di evitare lo sfregamento (con conseguente rottura) delle piastrelle antecedente alla posa del fugante.

According to the supplier of the grouting, its size shall be enough to ensure a suitable resistance of the flooring in order to avoid any vertical movement, which can be caused by a wrong levelling of the base and crack the grouting.

Lo spessore delle fughe inoltre, in accordo con il fornitore del fugante stesso, dovrà essere tale da garantire una adeguata robustezza della pavimentazione al fine di evitare che eventuali movimenti verticali (causati da un non adeguato livellamento del sottofondo) possano fessurare le fughe stesse.

Suitable laying is ensured only if epoxy grout is used.

La posa viene garantita solamente in presenza di fughe di tipo epossidico.

39

 $X \leq 40$ cm

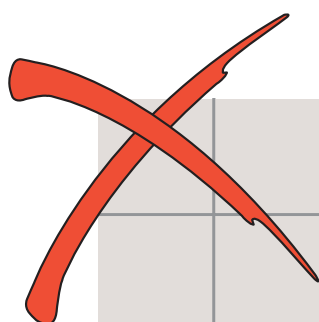
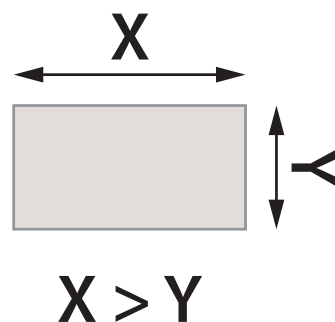
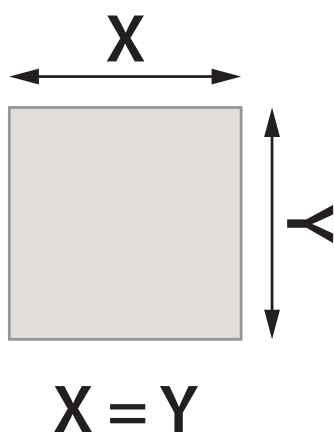

OK!

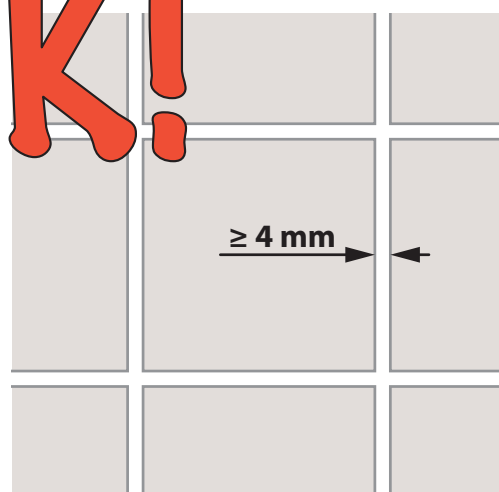

DIFFERENT FORMATS

For dimensions different from those indicated above, contact your trusted dealer for any information on feasibility, on the type of installation and the type of adhesive to be used.

FORMATI DIFFERENTI

Per dimensioni diverse da quelle indicate qui sopra, rivolgersi al proprio rivenditore di fiducia per eventuali indicazioni sulla fattibilità, sul tipo di posa e sul tipo di collante da utilizzare.



40

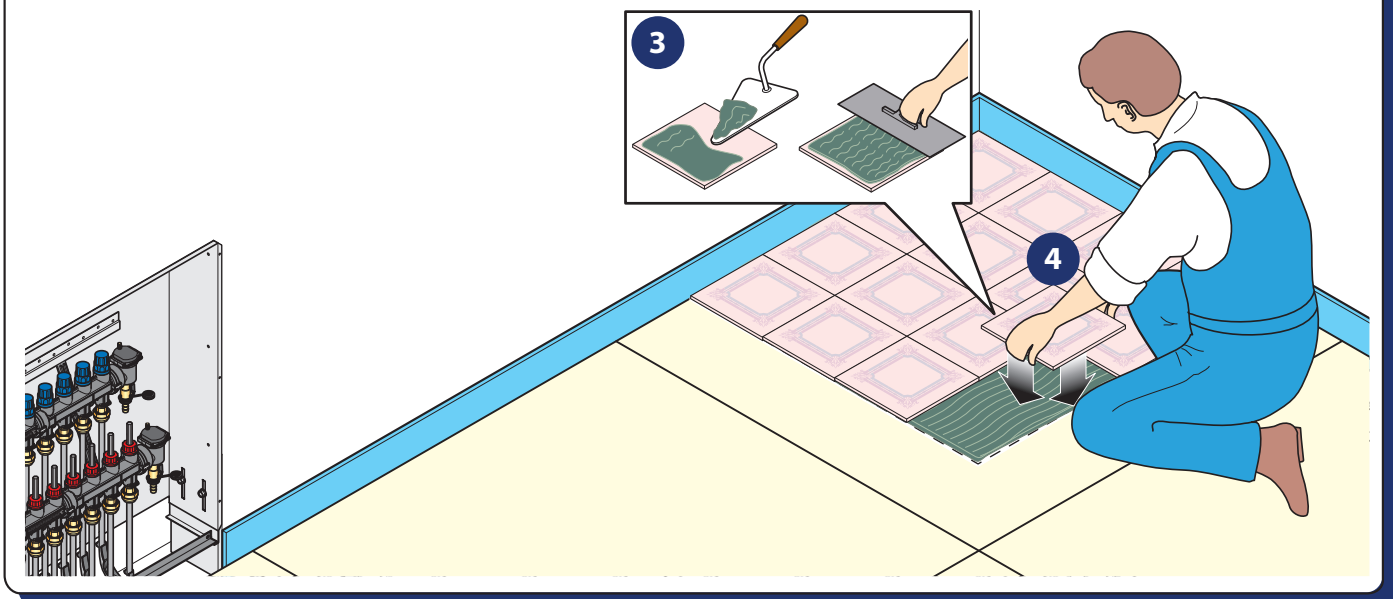
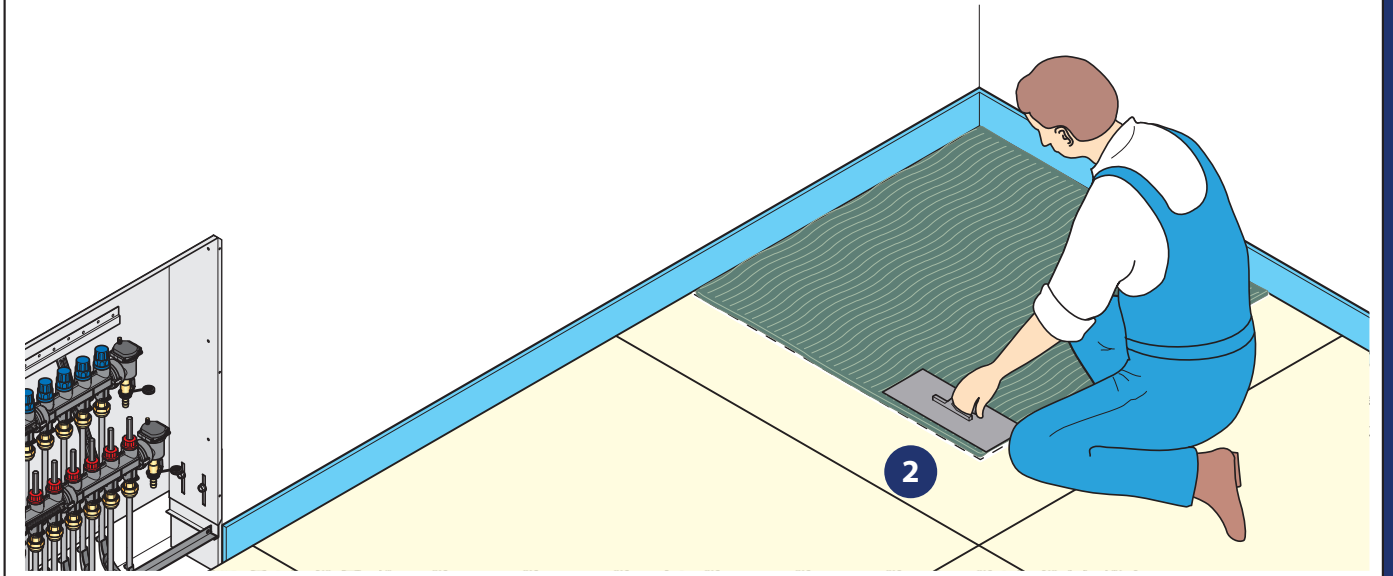
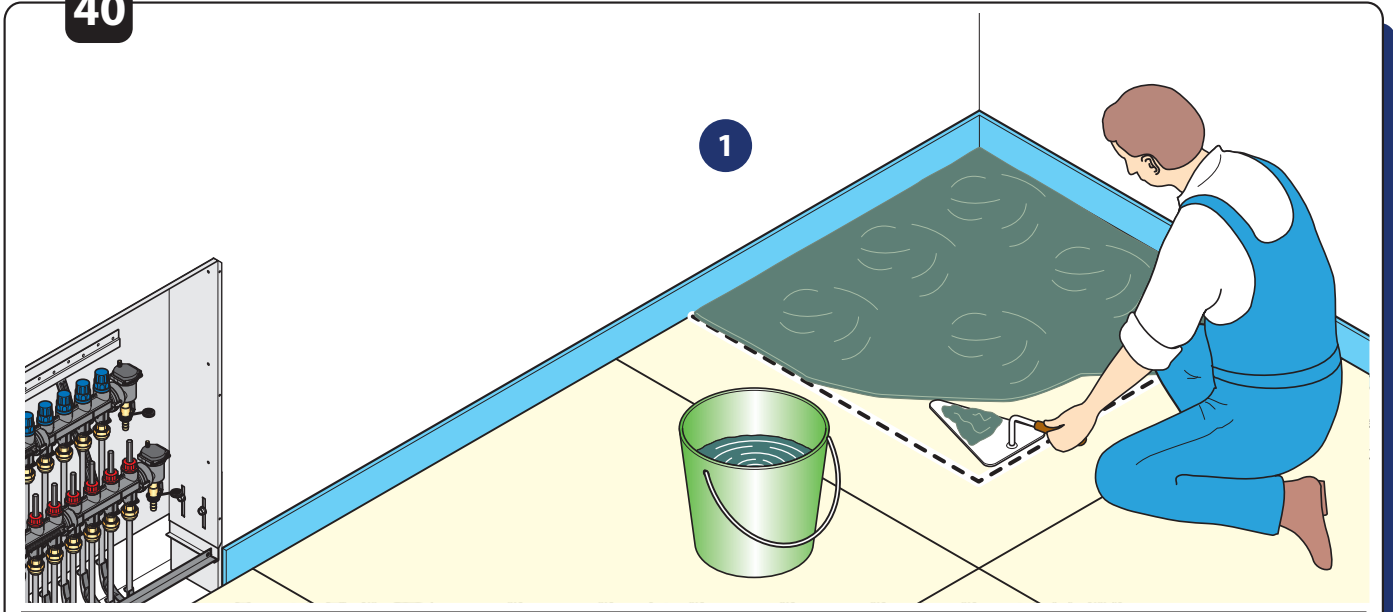



WOODEN FLOORING

 The gluing of wooden floorings is **FORBIDDEN** since the change in temperature and humidity on the flooring itself can cause cross tension between covering and weight distribution layer and raising of the flooring.

RIVESTIMENTI LIGNEI

 L'incollaggio dei rivestimenti lignei è **VIETATO**, in quanto le variazioni termo-igrometriche nel rivestimento stesso creano tensioni trasversali tra il rivestimento e il ripartitore provocando l'inarcamento o il sollevamento dei bordi del pacchetto incollato.

41

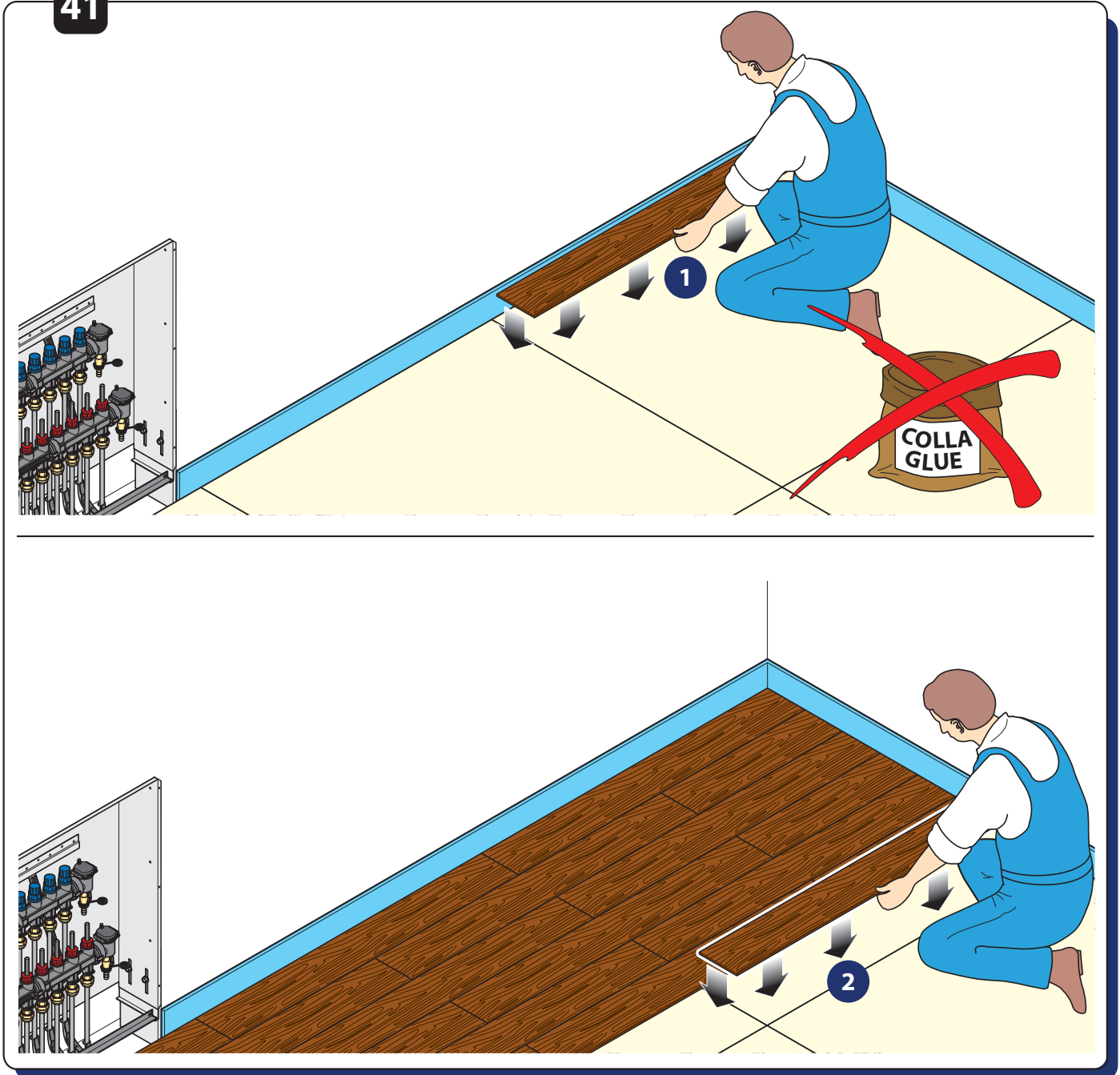

OTHER FLOORINGS

In case of ceramic or wooden flooring please contact RDZ Technical Department.

ALTRI RIVESTIMENTI

Per la posa di rivestimenti diversi dai ceramici o lignei contattare l'ufficio tecnico RDZ.

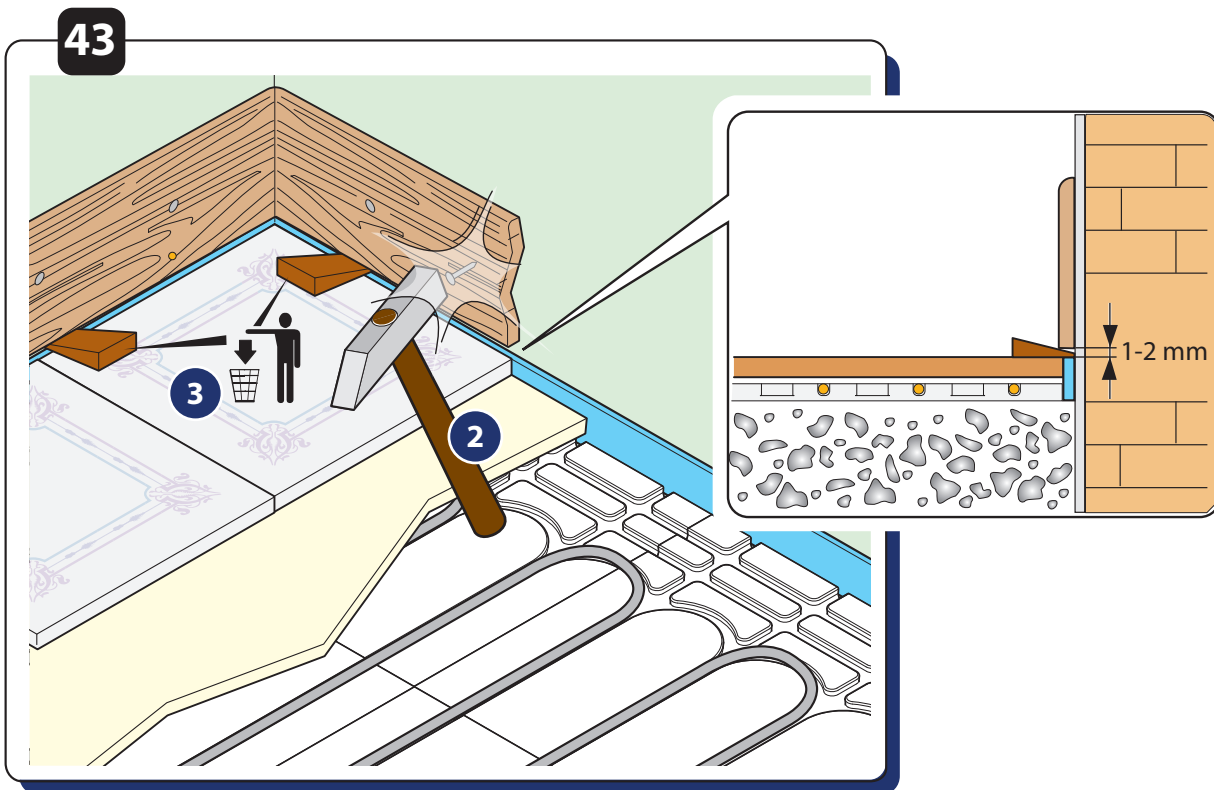
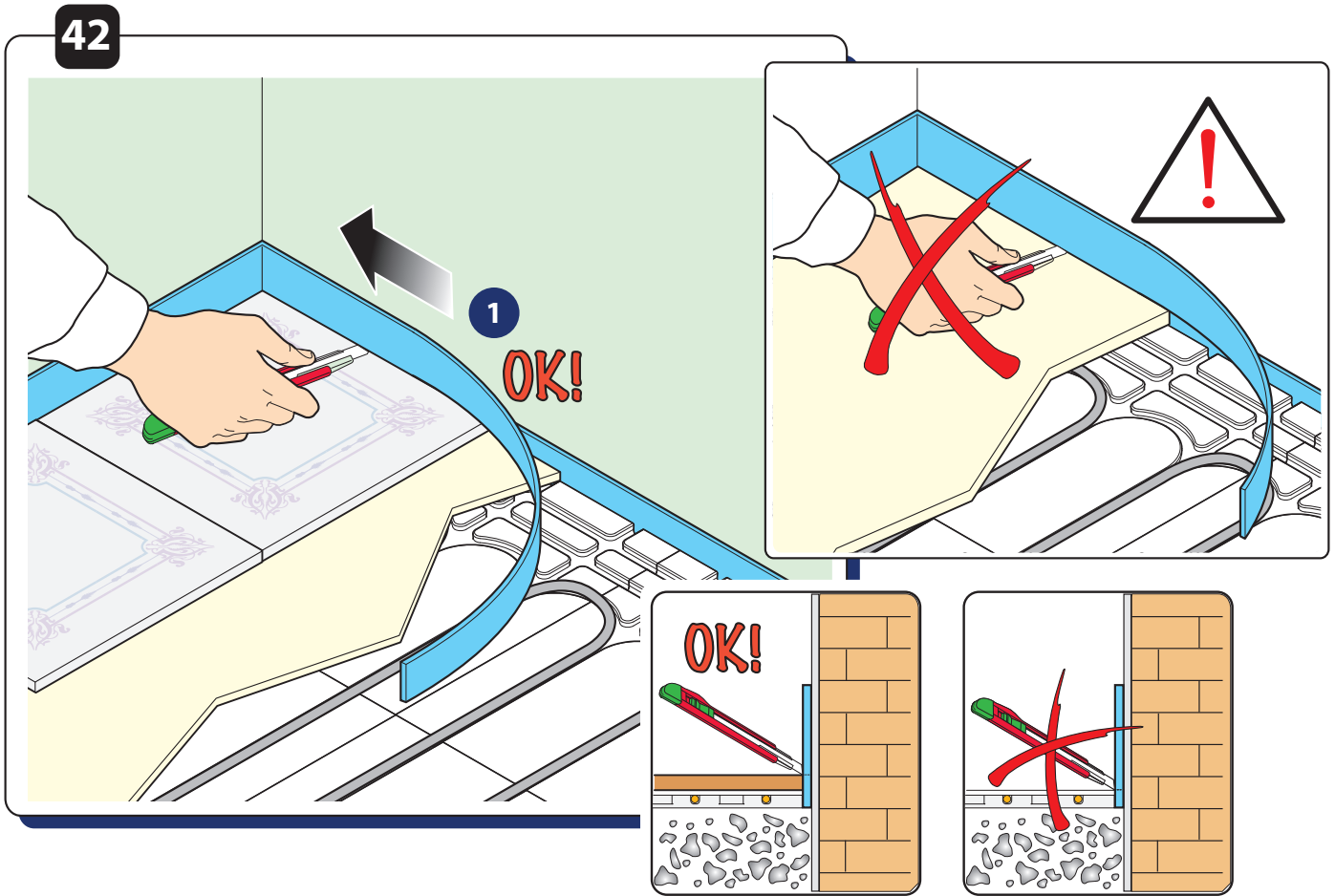

Fix the skirting board to the walls only, do not fix it to the floor! otherwise the flooring can get broken!

Fissare il battiscopa unicamente alle pareti, non ancorarlo alla pavimentazione! Pericolo di rottura del rivestimento!



4.8 | ADVICE FOR USE - CONSIGLI DI UTILIZZO

The system shall be switched on to reach the project temperature gradually.

The first activation starts with water at 20°C -25°C, which shall be gradually increased with 3°C a day until the maximum set temperature has been reached.

L'impianto va avviato e portato alla temperatura di progetto con gradualità.

Il primo avviamento comincia con il fluido ad una temperatura compresa tra i 20°C -25°C per essere gradatamente aumentata nel periodo successivo di 3°C al giorno fino al raggiungimento della massima temperatura prevista.

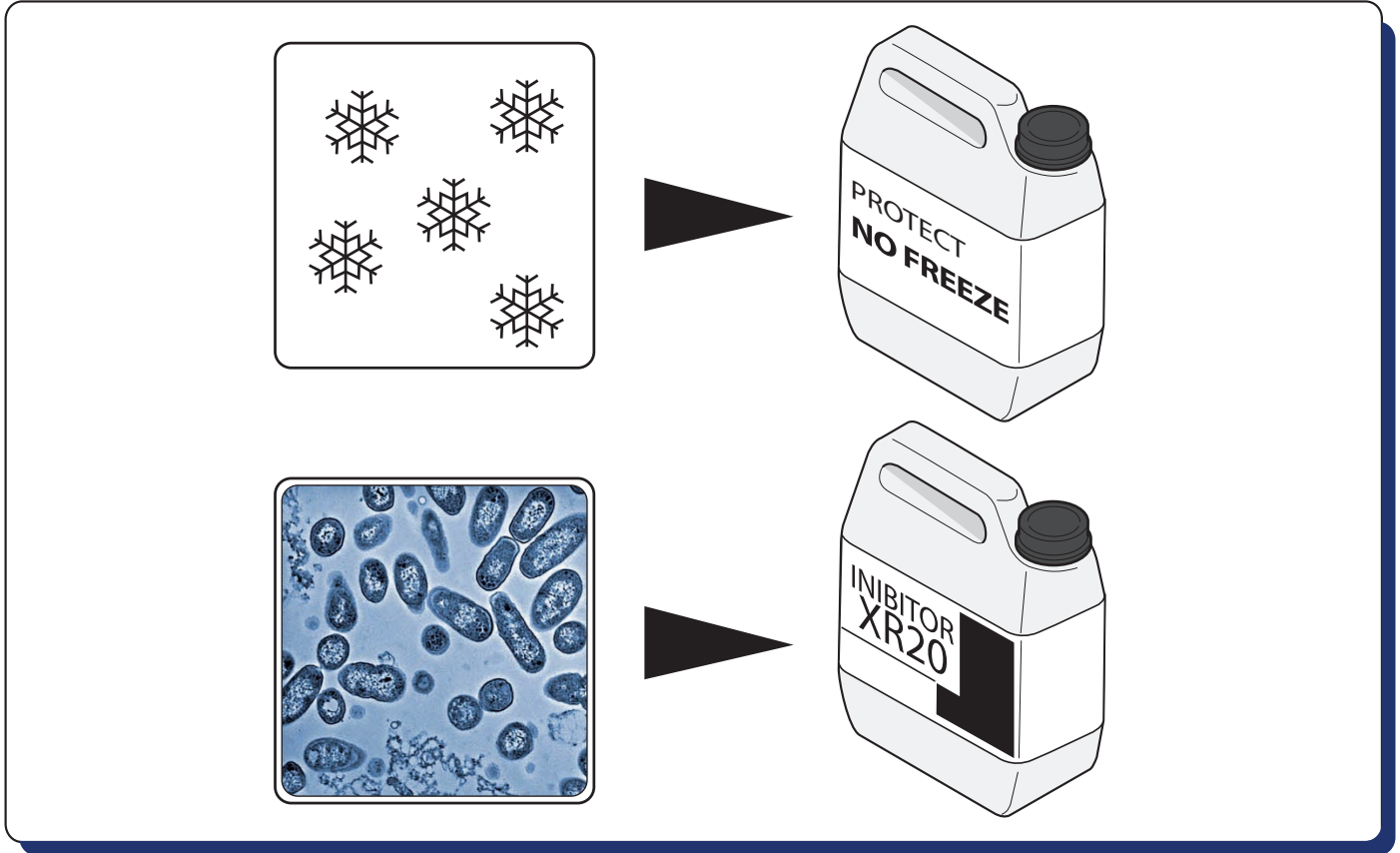

rdz.it/qr?r=00000



FAG0AZ008AB.00
03/2021



RDZ S.p.A.

🏠 V.le Trento, 101 - 33077 SACILE (PN) - Italy

☎ Tel. +39 0434.787511 📠 Fax +39 0434.787522

✉ info@rdz.it 🌐 www.rdz.it

**COMPANY WITH
QUALITY SYSTEM
CERTIFIED BY DNV GL
= ISO 9001 =**